

PUBLICATION

## DOUBLE-DECK DESTINATION CONTROL SYSTEM

Janne Sorsa  
E-mail: [janne.sorsa@kone.com](mailto:janne.sorsa@kone.com)  
Marja-Liisa Siikonen  
E-mail: [marja-liisa.siikonen@kone.com](mailto:marja-liisa.siikonen@kone.com)

This paper was presented at **ELEVCON** HELSINKI 2006, the International Congress on Vertical Transportation Technologies and first published in IAEE book "Elevator Technology 16", edited by A. Lustig. It is a reprint with permission from The International Association of Elevator Engineers **IAEE** [website [www.elevcon.com](http://www.elevcon.com)].

## ABSTRACT

Double-deck elevators are used in tall buildings to reduce the core space occupied by elevators. The handling capacity with double-deck elevators is approximately 1.5 times the handling capacity of single-deck elevators when considering different traffic patterns. In an up-peak situation, double-deck elevators stop at every other floor thus reducing the number of stops during the round trip to about half compared to single-deck elevators. If a destination control system is used with double-deck elevators, the number of stops during the round trip can be decreased further. In this article, a destination control system for double-deck elevators is presented and its performance is compared to conventional double-deck elevators as well as to single-deck elevators.

Keywords: Double-deck, destination control, simulation, genetic algorithm

## 1 INTRODUCTION

In high-rise buildings double-deck elevators save a considerable amount, about 30%, of the building elevator core space compared to single-deck elevators. Double-deck elevators are best suited to large plated buildings with an even population. The requirement of even floor heights in a building starts to be past as the adjustable distances between the decks become more common among the manufacturers.

The double-deck elevator was invented in 1930's, but most double-deck elevators were not installed until after the 1970's. First they were placed in North America, and later in the 1990's mostly in Asia and Europe. Within a couple of years, there will be about 700 double-deck elevators in total in operation world wide in more than 50 buildings. In the early phase, double-deck systems were found to be somewhat slow since there were so many stops where only one of the two decks was serving passengers. Kavounas (1989) showed theoretically that in an up-peak with a good system no more than one sixth of the probable stops should be those where only one deck is serving (figure of merit). In the 1990's, microprocessor technology was adopted in double-deck elevators and they became more efficient. All the existing double-deckers use the conventional full collective control system with up and down call buttons. Destination control was launched in single-deck elevators in the 1990's. For double-deck elevators, this system was introduced recently by Fortune (2005) but no such installations exist yet.

This article describes the existing double-deck control principles and utilization of a genetic algorithm in conventional and destination double-deck controls. The effect of lobby arrangements is studied and finally the performance of alternative elevator solutions is compared.

## 2 CONVENTIONAL DOUBLE-DECK CONTROL SYSTEMS

### 2.1 Known double-deck control principles

Control systems for traditional up- and down-buttons are based on the principle of full collective control. The nearest car in the travel direction serves the landing calls. Car calls given by passengers inside the car are always served in sequential order. The elevator never changes its direction while there are car calls left to serve. Typically, the control system assigns active landing calls to elevators continuously, which makes it possible for the control system to change the assignment dynamically.

Double-deck control systems need to maximize the coincident stops, where there are waiting passengers on, or travelling passengers to, adjacent floors. Typically, the control system selects the elevator to serve a particular call and assumes a specific deck will serve the floor in question. Then, if there happens

to be a landing call on the adjacent floor, the control system can use also the other deck to serve the coincident call.

The strategy for how to select the deck to serve a particular floor affects the passenger experiences of service level. A simple fixed strategy would be to select either the leading or the trailing deck for a particular landing call. For example, assume that the elevator is travelling downwards and there is a landing call assignment for this elevator at floor 8. If the trailing deck strategy were used, the control system would first allocate the upper deck to serve this floor, and then continue to check a possible landing call at floor 7. The fixed strategy leads to unbalanced loads between the decks because a certain deck is preferred for serving landing calls. Another approach would be to use more dynamic rules to determine the serving deck for landing calls. Siikonen (1998) describes a simple rule for selecting the less crowded deck. In the above example, if the lower deck has three passengers and the upper deck has six passengers, the control system would select the lower deck to serve floor 8 and then check for another call at floor 9. If the dynamic strategy is used, the loads of the decks become more balanced and the space in the elevator is utilized more efficiently.

## 2.2 Genetic algorithm

A modern approach is to use mathematical methods to optimize the service quality of the elevator group. The genetic algorithm (GA) is an optimization method that has been successfully applied to an elevator call allocation problem (Tyni and Ylinen, 2001; Sorsa et al. 2003). The genetic algorithm is a useful tool to solve difficult combinatorial optimization problems, where a huge number of feasible solutions exist and the search space cannot be explored as efficiently as in traditional continuous optimization problems (Bertsimas and Tsitsiklis, 1997).

In an elevator call allocation problem, the number of feasible solutions is  $LC$ , where  $L$  is the number of elevators and  $C$  is the number of active landing calls. For multi-deck elevators, the number of solutions is  $(D-L)C$ , where  $D$  is the number of decks in an elevator. For example, if there are 10 active landing calls in a group of eight double-deck elevators, the number of feasible solutions is 1610 or about 1012. If the processing of one solution candidate takes one microsecond, exploration of all possible solutions would take about one million seconds, or roughly 11 days. Clearly this kind of computational task is unfeasible for group control, which operates in real time.

The method borrows its terminology from evolutionary biology. A solution proposal is presented by a chromosome, which encodes the variables of the underlying optimization problem. In elevator call allocation, chromosomes consist of allocation proposals for the active landing calls. The values of a particular variable represent the elevators, or decks of a double-deck elevator, that can serve this particular landing call. Typically, the chromosomes in the genetic algorithm are presented by a string of integers.

In Figure 1 below, an example situation is shown for two double-deck elevators E1 and E2. The decks of the elevators are marked “D1”, “D2”, “D3” and “D4”. The triangles on the right-hand side of the elevator shafts represent active landing calls. They are related to specific locations in the chromosomes on the right, which represent two solution candidates for the current system state. The circles in the shaft represent car calls of decks D1 and D2.

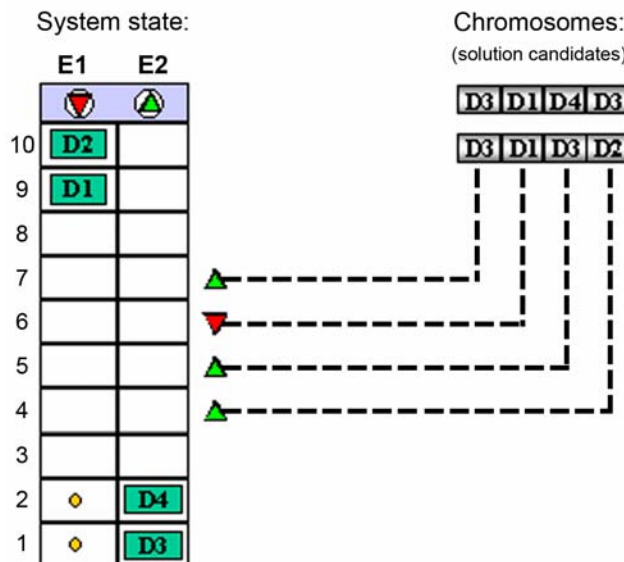

**Figure 1. State of an elevator system and two chromosomes for GA**

The genetic algorithm starts with a randomly selected set (or population) of solution candidates, chromosomes, and evaluates the fitness of them. Some of the most promising candidates will be used as parents, when creating a new generation of solution candidates, the offspring. This process is called the crossing-over. Two parent chromosomes are cut from a specific location of the chromosome. Then the ends of the parent chromosomes are mixed to create two new child chromosomes. For example, if the chromosomes of the above example are denoted by (D3 D1 | D4 D3) and (D3 D1 | D3 D2) with the cut location marked as '|', the new offspring would be (D3 D1 D3 D2) and (D3 D1 D4 D3).

The algorithm produces new generations until the best candidate remains unchanged or a predefined number of generations have been created. The theory of genetic algorithms predicts that beneficial properties of chromosomes survive. In the above example, the beginning of both chromosomes is “D3 D1”, which means that the lower deck of elevator 2 will serve the up-call on floor 7 and the lower deck of elevator 1 will serve the down-call on floor 6. If this turned out to be a good strategy, most or all of the chromosomes in future generations would begin with “D3 D1”.

The fitness of each solution candidate is evaluated by creating the explicit routes of each elevator, assuming the particular solution candidate would

become the final allocation decision. The estimated time of arrival (ETA) at each stop on the route is calculated from elevator dynamics. The final fitness value is based on these arrival times.

The optimization objectives applicable in the call allocation problem are those such as call time, waiting time, journey time and energy consumption. With multi-objective optimization techniques, energy can be saved in light traffic while maintaining a specified maximum level of call times (Tyni, 2005). Call time is defined as a sum of the time the call has been active and the estimated time of arrival. Passenger waiting time is estimated by multiplying the previously calculated call time with an estimated number of passengers behind the landing call. In a conventional control system, the exact number of passengers is not known, but can be forecasted from people-flow statistics gathered by the group control (Siikonen, 1997).

The two chromosomes in Figure 1 with elevator routing and estimated times of arrivals at stops on route are shown in Figure 2 below. The triangles in the elevator shaft indicate the landing call allocation for this particular elevator. The call times along the shown routes are listed in Table 1 below, where the “Total” row indicates the final fitness value for the particular solution candidate. For simplicity, it is assumed that one floor flight takes two seconds and the stop time is ten seconds. In the real control system, the flight times are calculated exactly from elevator dynamics and the stop time is calculated from the estimated number of passengers entering or exiting.

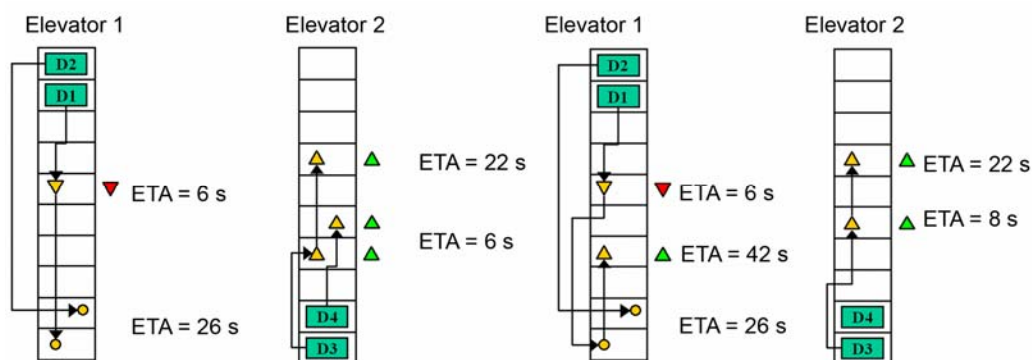

**Figure 2. Double-deck elevator routing with the given solution candidates**

It is easy to see that the left-hand solution outweighs the right-hand solution where the up-call at the 4th floor has a very long estimated time of arrival. In the course of the execution, the genetic algorithm produces also “bad” candidates as in the right-hand solution, but always converges to “good” solutions as in the left-hand side of Figure 2. The genetic algorithm ensures that in the end a representative sample of the complete search space has been explored and the found optimal solution is with high probability the globally optimal solution.

**Table 1. Call times along the routes of the given solution candidates**

Call Floor	Call Direction	Candidate 1		Candidate 2	
		Serving Deck	Call Time	Serving Deck	Call Time
4	Up	D3	6	D2	42
5	Up	D4	6	D3	8
6	Down	D1	6	D1	6
7	Up	D3	22	D3	22
<b>Total</b>			<b>40</b>		<b>78</b>

### 3 DOUBLE-DECK DESTINATION CONTROL SYSTEM

Instead of up- and down-call buttons, passengers use a numeric keypad on the Destination Operation Panel (DOP) to enter the destination floor. The control system immediately assigns an elevator to the passenger, and displays it on the DOP. Then the passenger walks in front of the assigned elevator and waits for its arrival.

The genetic algorithm can be applied also to the destination call allocation for double-deck elevators. Figure 3 shows the difference of destination control to full collective control. The chromosome contains one variable for each destination call regardless on the departure floor of the passenger. Landing call positions in the chromosome are now replaced by the destination call positions. The control system knows both the departure and destination floor of each passenger and the exact number of passengers in the system. The walking times of passengers is calculated from the known locations of the DOPs, which ensures that the passenger will have enough time to walk to the elevator. The control system reserves extra space in the car and a longer walking time for disabled passengers. This functionality is initiated either by a special call button in the DOP or by access cards.

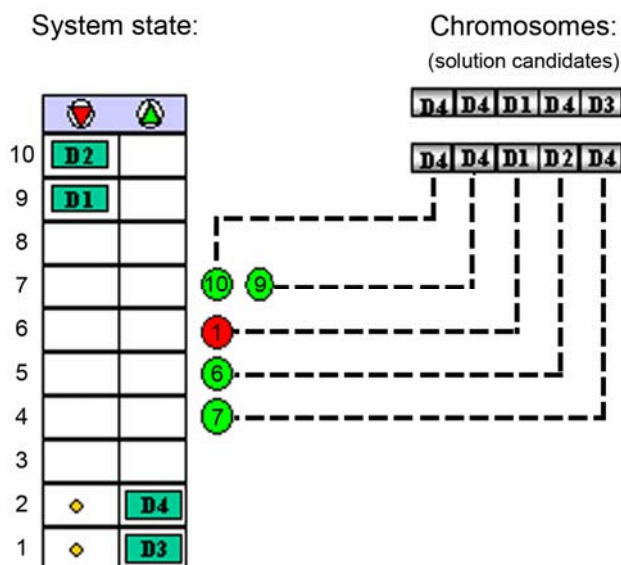

**Figure 3. Elevator group with five arriving passengers giving destination calls (number inside the circle)**

Elevator routing with destination calls takes into account this extra information available, as shown in Figure 4. Now it is possible to estimate individual waiting and journey times of passengers by using the estimated times of arrival. In practice, the order and timing of passenger arrival restricts the freedom of the control system. Usually, only one destination call needs to be assigned as other passenger calls are fixed. Figure 4 shows that the basic strategy of maximizing the number of coincident stops does not necessarily lead to the best result considering all the optimization objectives.

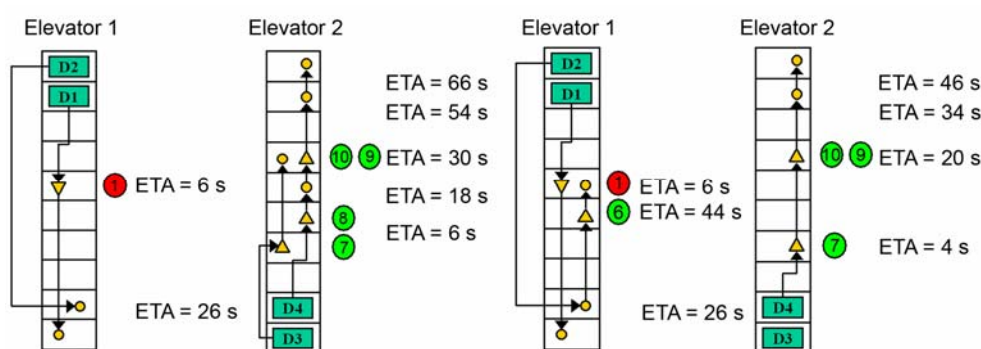

**Figure 4. Double-deck elevator routing with destination calls**

By using artificial intelligence (Siikonen, 1997), the control system can change the optimization objective according to a forecast traffic condition. Waiting time is optimized during light traffic conditions when the boosting effect of destination control is not needed. At morning up-peak and for mixed lunch-hour traffic, journey time optimization boosts the handling capacity of the elevator group to its maximum. Journey time optimization may lead to longer waiting times but a shorter time to destination. Table 2 shows the waiting and journey time estimates for the solution candidates of Figure 4. Candidate 1 is clearly the better alternative if waiting time is used as the criterion. On the other hand, Candidate 2 produces a shorter average journey time.

**Table 2. Values of optimization objectives for the two solution candidates**

Departure Floor	Destination Floor	Candidate 1			Candidate 2		
		Serving Deck	Waiting Time	Journey Time	Serving Deck	Waiting Time	Journey Time
4	7	D3	6	42	D4	4	20
5	6	D4	6	18	D2	44	56
6	1	D1	6	26	D1	6	26
7	9	D4	30	54	D4	20	34
7	10	D4	30	66	D4	20	46
<b>Total</b>			<b>78</b>	<b>206</b>		<b>94</b>	<b>182</b>

## 4 LOBBY ARRANGEMENTS

### 4.1 Even/odd arrangements

Independent of the manufacturer, all double-deck installations have basically the same type of lobby arrangement. Passengers are guided to take either the upper or lower deck if they are destined either to even or odd floors. Fixed signs of served floors are used in the lobby to guide passengers. Escalators are usually needed to carry people to and from the floor of upper deck. Also transportation for disabled passengers may be needed

In serving incoming traffic, the elevator stops only at every other floor, thus decreasing the number of stops to about half and increasing handling capacity in up-peak. The even/odd service mode is maintained by some controls, but most often the elevators start to serve every floor with both decks after they stop at the first landing call on an upper floor.

### 4.2 Flexible guidance to both decks

With destination double-deck control, it is not obligatory to use the fixed even/odd arrangement any more, if the DOPs are located at the entrance floor close to the escalators. Then the control system can guide passengers to proper decks, producing a minimum number of stops. At elevator lobbies of lower and upper decks probably extra DOPs are needed for the case where a passenger has missed the assigned elevator.

### 4.3 Effect of walking distances

Up-peak simulation was run with increasing traffic intensities to study the effect of the lobby arrangement. The basic case is a normal double-deck lobby, in which the Destination Operation Panels (DOPs) are located close to the elevators. The walking times vary from 2 seconds to 10 seconds. Another situation arises, if the DOPs are integrated to security systems in turnstiles and control system assigns the destination floor for the passenger. In this case, the journey with the escalator causes very long walking times for some passengers. The walking times vary from 2 seconds to 40 seconds. Even in this case, there are some very short walking distances as some of the passengers arrive in the lobby without going through the turnstiles. The walking time distributions for both cases are shown in Figure 5a. The passengers, who need to take an escalator from the ground floor to the upper lobby, are clearly visible in the distribution around the 35-second mark. Respectively, those who walk from the turnstiles to the ground floor lobby show walking times of around 20 seconds.

The resulting times to destination during the up-peak are shown in Figure 5b. The time to destination is clearly longer for the case where DOPs are integrated into the turnstiles. This is of course to be expected, because walking time is included in time to destination. The carload factors shown beside the curves show that the loading of the elevators is not greatly affected

by the long walking distance. The carloads are smaller in the case of DOP integration with turnstiles, which indicates that group control cannot fill the cars as efficiently as in the case where the DOPs are close to the elevators.

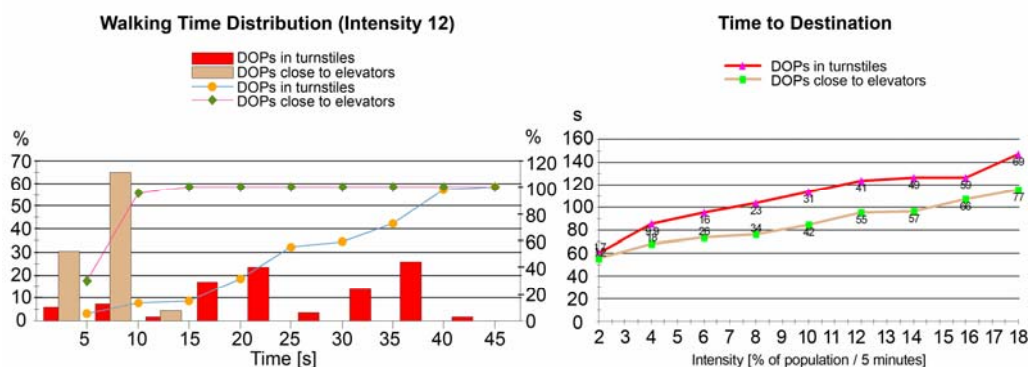

**Figure 5. Walking time distribution for different floor layouts at 12% intensity and simulated times to destination**

According to simulations, it seems that the handling capacity of the elevator group is not affected by arranging the flexible guidance to either lower or upper lobby. However, the service quality of the elevator group deteriorates, and some long waits in the lobby arise. In this study, the walking speed of the simulated passengers was equal to the walking speed assumption in the group control. Even if the assumed walking speed in the group control is set to a safe level, long walking distances greatly increase the risk that slowly walking passengers can miss their assigned elevator.

## 5 COMPARISON OF ALTERNATIVE ELEVATOR ARRANGEMENTS

Pure up-peak traffic was simulated in an office building with six elevator shafts. There is one entrance floor in the building and 18 populated floors, each of them having 100 persons. Six elevators with a speed of 3.5 m/s serve the building. Both single- and double-deck elevators were simulated, as well as a conventional full collective control system and destination control system. The purpose of the comparison was to find out the maximum handling capacity of each of these options in up-peak situation.

The calculated up-peak handling capacities for conventional single-deck and double-deck groups are 9.1% and 18.3%. With an up-peak formula for destination control, the handling capacity is boosted to 15.7% with single-deck elevators and to 32.8% with double-deck elevators (Sorsa et al, 2006). The up-peak performance parameters for these options are shown in Table 3. The values are calculated with an 80% car-load factor, and show the maximum handling capacity of the group in each case.

**Table 3. Calculated up-peak performance of the optional arrangements**

Elevators	Control System	Handling Capacity	Round Trip Time	Departure Interval
		% of pop / 5 min	s	s
Single-deck	FC	9.1	185.3	30.9
Single-deck	DCS	15.7	107.2	17.9
Double-deck	FC	18.3	183.4	30.6
Double-deck	DCS	32.8	102.3	17.0

The simulated average times to destination for the four mentioned cases are shown in Figure 6 below. The average carload factor is shown above the curve. According to simulations, the up-peak handling capacities are about the same as calculated in Table 3. Time to destination stays below 100 seconds with carload factors below 80% in all other cases except conventional single-deck elevators. In up-peak with a double-deck destination control system, typically less than 5% of all stops are those where only one deck is serving.

### Time to Destination

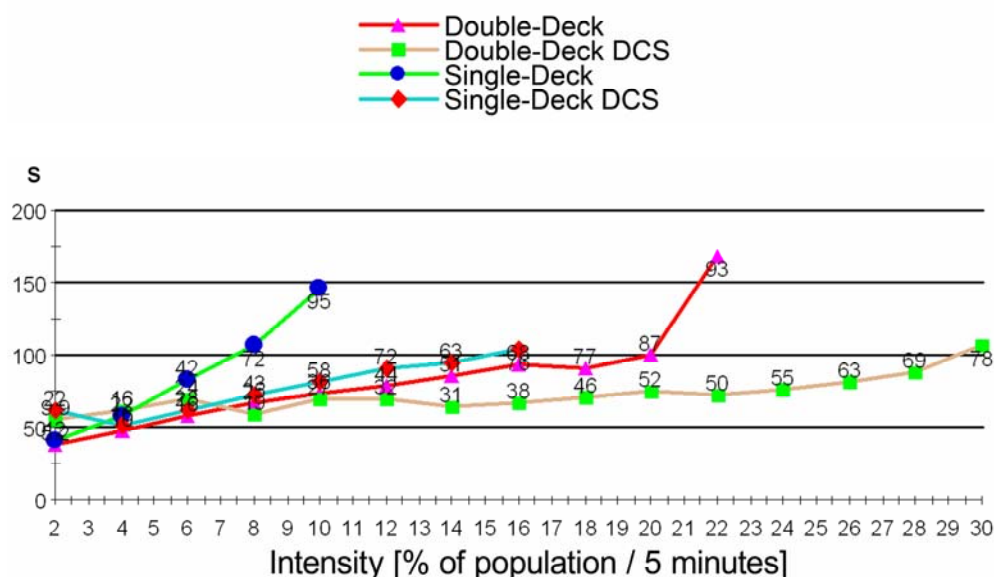

**Figure 6. Simulated times to destination for different elevator arrangements**

## 6 CONCLUSION

In this article, the effect of destination control on double-deck control systems was discussed. The genetic algorithm is used to allocate passenger destination calls intelligently to the best elevator and deck. The optimization objectives vary according to the passenger traffic demand. During normal traffic intensity, passenger waiting times become short but during heavy traffic peak passenger time to destination is optimized, which increases the handling capacity.

Destination control brings freedom to the layouts of double-deck groups and to the lobby arrangements. If a passenger gives the call already at a turnstile or in the beginning of an escalator, the walking distances to the lobby will be long. This presents a challenge for the control system, which should consider the walking times in assigning the calls to elevators.

The up-peak handling capacities of single- and double-deck groups using six hoist ways were compared. Double-deck destination increases handling capacity by about 50-60% compared to conventional double-deck and about 260% compared to a conventional single-deck group. The filling of elevator decks and carloads become more optimal with the exact information of the number of waiting passengers and their destinations.

## REFERENCES

- Bertsimas, D. and Tsitsiklis, J.N. (1997). Introduction to Linear Optimization. Athena Scientific, Belmont, Massachusetts. 587 pp.
- Fortune, J.W. (2005). Predestination hall call selection for double deck lifts (3D encoding). Elevator World, Vol. 53 (8), pp. 126-133.
- Kavounas, G.T. (1989). Elevator analysis with double deck elevators. Elevator World, (11). pp 65-72.
- Siikonen, M-L. (1997). Elevator group control with artificial intelligence. Helsinki University of Technology, Systems Analysis Laboratory, Research Reports A67. 32 p. ISBN 951-22-3588-9.
- Siikonen, M-L. (1998). Double-deck Elevators: Savings in Time and Space. Elevator World, Vol. 46 (7), pp. 65-69.
- Sorsa, J., Hakonen, H., Siikonen, M-L. (2006). Elevator Selection with Destination Control System. Elevator World, Vol. 54 (1), pp. 148-155.
- Sorsa, J., Siikonen, M-L., Ehtamo, H. (2003). Optimal control of double-deck elevator group using genetic algorithm. International Transactions in Operations Research, Vol. 10 (3), pp. 103-114.

Tyni, T. and Ylinen, J. (2001). Genetic Algorithms in Elevator Car Routing Problem. In: Proceedings of the Genetic and Evolutionary Computation Conference (GECCO-2001), Spector, L. et al. (Eds.), San Francisco, California, United States, Morgan Kaufman Publishers, pp. 1413-1422.

Tyni, T. (2005), Soft computing Control Models for Elevators, Ph.D. Thesis, Tampere University of Technology. 145p.