

Dedicated to People Flow™



MANAGING THE FLOW OF PEOPLE AND GOODS IN MEDICAL BUILDINGS

KONE solutions for medical facilities

A full range of people and goods flow solutions for demanding medical facilities

A modern hospital or medical facility offers many challenges for managing the flow of people and materials. Patients in beds need to be transported quickly and smoothly with accompanying staff and medical equipment. Food, laundry, medical supplies and equipment must be transported without interruption. Elevators are used by both patients and visitors, many of whom may have special mobility requirements.



KONE has a long history of designing, implementing, maintaining and modernizing the people and goods flow solutions in demanding hospital environments. By taking each phase of the equipment's lifetime into consideration, KONE works to keep the facility operating at maximum efficiency, with low total cost of ownership.

KONE solutions for medical facilities

1. Passenger elevators
2. Bed elevators
3. Service elevators
4. Helipad elevators
5. Escalators
6. Automatic building doors
7. Gates
8. Loading bays
9. Hermetic sealing doors
10. Automated guided vehicles integrated with elevators and building management systems
11. Destination control systems for elevator groups

The entire product portfolio – built for demanding medical applications

KONE supplies a full range of elevators, escalators and building doors to ensure that patients, staff, visitors and goods move smoothly, efficiently and reliably into, within and out of the hospital.

Elevators

When designing KONE elevators for use in hospitals, we have paid particular attention to safety, reliability, smooth and quiet operation, eco-efficiency and hygiene. All KONE elevator solutions are powered by KONE EcoDisc® and utilize proven KONE components.

Energy efficient and cost-effective

- Energy efficient drives and hoisting systems with regenerative features
- Energy-saving LED and fluorescent lighting solutions
- Standby solutions to save energy when equipment is not in use

Efficient management of people and goods flow

- KONE Polaris™ destination control system to improve user guidance and boost traffic handling
- Centralized elevator and escalator monitoring, command and management, and exchange of data between systems, with KONE E-Link™
- Easy exchange of data and integration with other facility management systems through open standard interfaces

Safe, smooth and reliable

- Accurate leveling to improve safety, comfort and ease of use, important for elderly and disabled people and when loading beds and trolleys
- Reliable permanent magnet based gearless KONE EcoDisc® hoisting units with excellent track record, more than 300 000 units in operation globally
- Meets the strictest requirements for electromagnetic compatibility: EN-12015 and EN-12016

Space-efficient construction

- KONE machine-room-less elevators save space, allowing more room for patient care and giving architectural freedom for design
- No need for a machine room on the roof, allowing flat roof structures. Helipad elevators can operate through the roof next to landing zone

Hygienic and visually pleasing

- Pleasing designs and colors, comforting for patients and staff
- Durable and easy-to-clean materials

Escalators

Escalators can ensure the smooth flow of people in large hospital building complexes and, for example, serve underground floors or car parks.

- Dedicated product range to match the anticipated traffic intensity
- Energy saving features like efficient drives, LED lighting and stand-by solutions
- Lubrication free chain is oil and odor free, easier to clean and maintain
- The possibility to connect escalators to central monitoring systems so they can be controlled and managed remotely from a single location even over a large hospital complex

Doors

KONE provides a full range of door solutions. KONE also supplies solutions for the movement of goods into the hospital, such as loading bays and gates.

- Solutions to reduce the loss of warm or cool air, making building heating or cooling more energy efficient
- KONE hermetic sealing doors are used for protection against X-ray radiation, or when extreme hygiene or resistance to fire or noise is needed

Understanding the flow of people and goods in hospitals

In hospitals the elevators are in constant use from early morning to late evening, every day of the week. A sudden increase in elevator service may occur during lunchtime or visiting hours. These and even extreme conditions such as a possible evacuation of the building need to be analyzed and simulated during the planning phase.

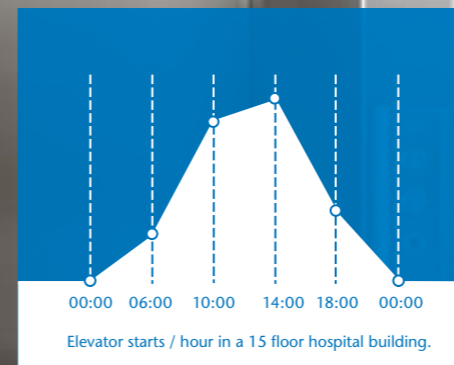

Elevator solutions for all medical applications

Elevators are essential for ensuring the smooth flow of people and goods in the hospital. KONE provides a full range of elevator solutions, for supplies and equipment, staff, visitors and patients, whether they are coming in the front door or landing on the roof. When designing solutions for the medical environment, our criteria are extreme reliability, safety and energy-efficiency, which lower the cost of ownership and the environmental impact. In hospital environments special attention is paid to hygiene. Materials have been carefully selected to be aesthetically pleasing and easy to clean.

KONE bed elevators

KONE bed elevators are designed especially for hospital environments, offering the following features:

- **Specialized car dimensions** – to accommodate the bed and medical equipment, with wide-opening doors and deep car size
- **Smooth loading and unloading** – precise leveling for easy entry of wheelchairs, beds and patients
- **Emergency/priority/remote calls** – for immediate availability during emergency situations
- **Quiet, smooth operation** – to prevent disturbance to traveling patients and in rooms near the elevator shaft
- **Flush-mounted operating panels** to avoid collisions with medical equipment
- **Indirect, non-glare lighting** and clear indicators to improve visibility and provide guidance for users



KONE passenger elevators

KONE passenger elevators are designed to transport visitors and staff smoothly and energy-efficiently.

- **Space efficiency** – maximum car sizes with minimum shaft dimensions. Increases passengers' convenience while saving construction costs
- **Machine-room-less** – enables elevator to serve the top floor – or even the roof – without a machine room on the roof of the hospital
- **Design** – wide selection of design alternatives to match the buildings architecture
- **Wide duty range** – to satisfy the people flow requirements of any hospital

KONE service elevators

To move heavy loads, you need an elevator that is designed specifically for that purpose:

- **Fast and durable hoisting** to cope with rough treatment
- **A smooth ride** to handle fragile loads
- **Accurate leveling** for easy loading and unloading
- **Full-width doors** that maximize use of space in the car

KONE elevator types and duty ranges for medical applications

	Nominal load		Travel (m)	Speed (m/s)
	(persons)	(kg)		
Bed elevators	17-53	1000-5000	up to 70	1.0-2.0
Service elevators	17-53	1000-5000	up to 23	0.6-1.0
Passenger elevators	8-17/21	630-1275/1600	40-80	1.0-3.5

For more detailed information about available car and shaft sizes, see separate planning information or contact your KONE sales representative.

KONE helipad elevators

In urban areas, often the best way to access the hospital in an emergency is by helicopter. Because of the safety areas around the helipad, the elevators to the roof have traditionally been located relatively far from landing spot, so valuable time is lost and the patient may be exposed to open air and rough weather. The KONE MonoSpace® elevator does not need a machine room on top of the shaft, so the elevator car can literally come through the hospital roof close to the helicopter as soon as it has landed. Several KONE helipad elevators are in operation in hospitals around the world.



As soon as the helicopter has landed, the KONE MonoSpace® elevator rises through the roof, providing the fastest way to take passengers into the hospital.

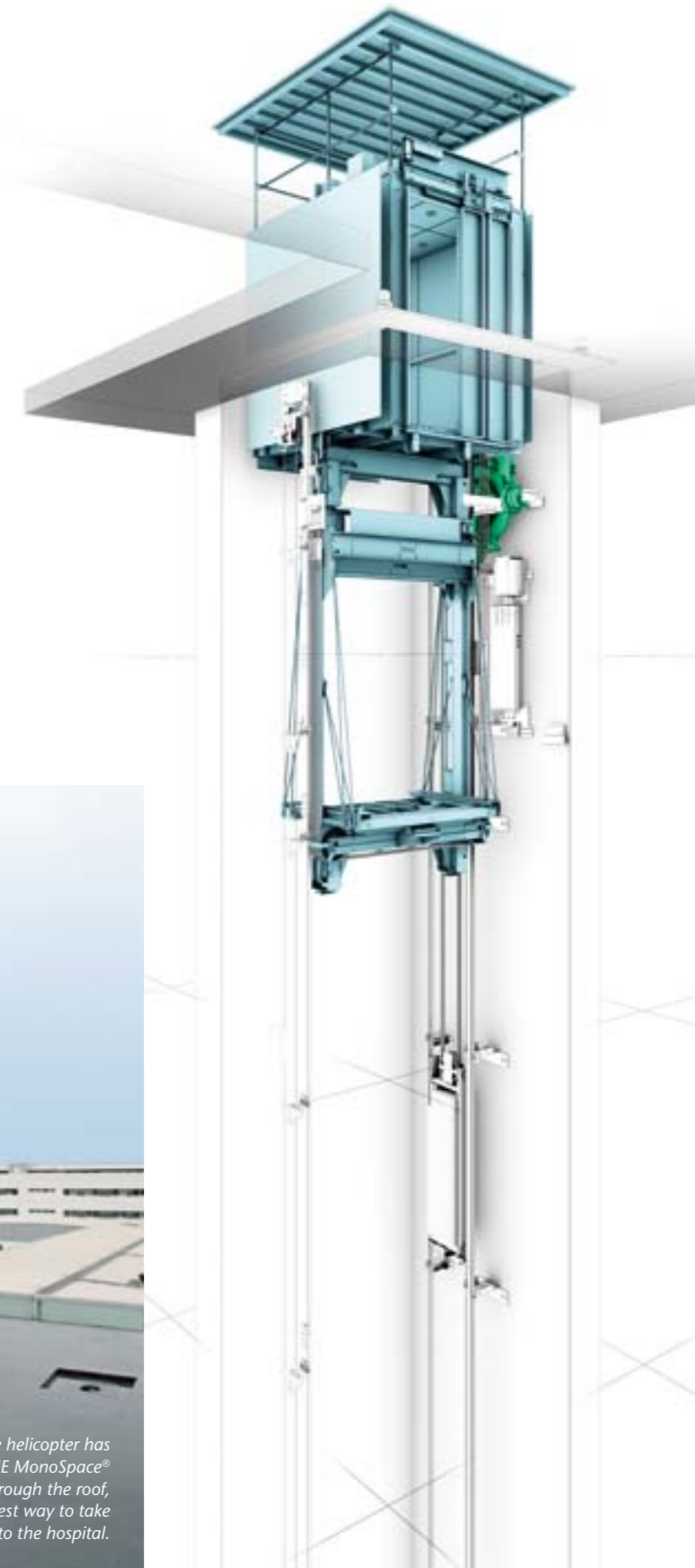

Eco-efficient™ elevators for medical facilities

The cost of owning an elevator is made up of three components: the purchase price, the cost of maintenance, and the running costs. Thanks to their dependability and energy-efficiency, KONE elevators significantly reduce the total cost of ownership.

KONE has constantly been the forerunner in developing the most energy efficient elevator hoisting technology in the industry, as can be seen in the chart on the right. The annual energy consumption of a typical mid-size elevator has been reduced from over 20,000 kWh to one third. The latest KONE energy saving options can squeeze this consumption even further, to close to 5000 kWh/year.

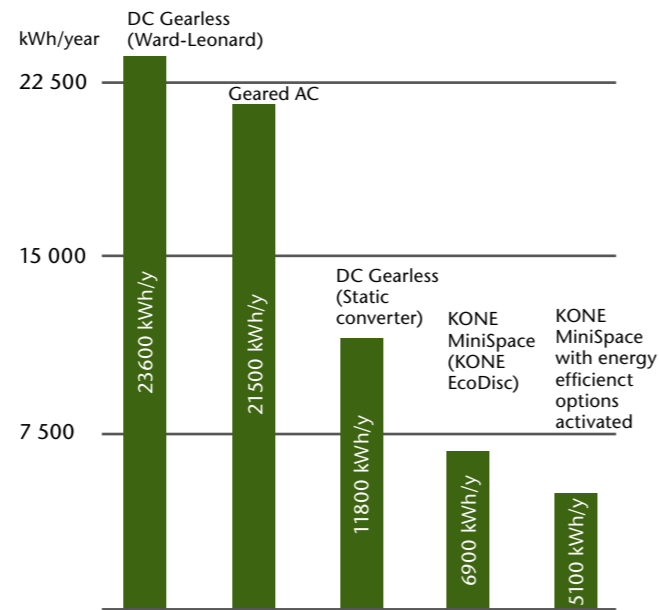

KONE's innovations in hoisting technology and eco-efficient solutions have dramatically decreased the energy consumption of KONE elevators.

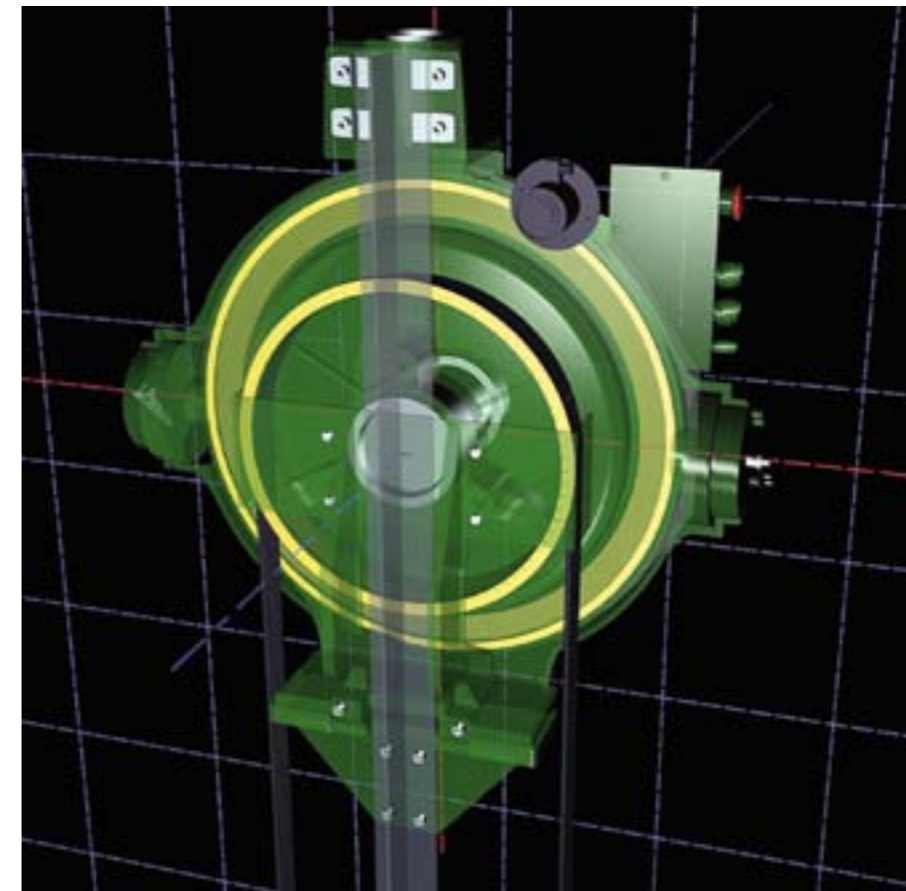

Efficient hoisting and energy regeneration
The very high mechanical and electrical efficiency of the KONE EcoDisc® saves a considerable amount of energy compared with other solutions: it consumes 50% less energy than a geared two-speed traction elevator and 70% less than a hydraulic elevator. It also recovers braking energy which can be converted into electricity for use elsewhere in the hospital. This regenerative feature alone can save 20-30% of the elevator's annual energy consumption.

The energy consumption of an eco-efficient™ KONE elevator

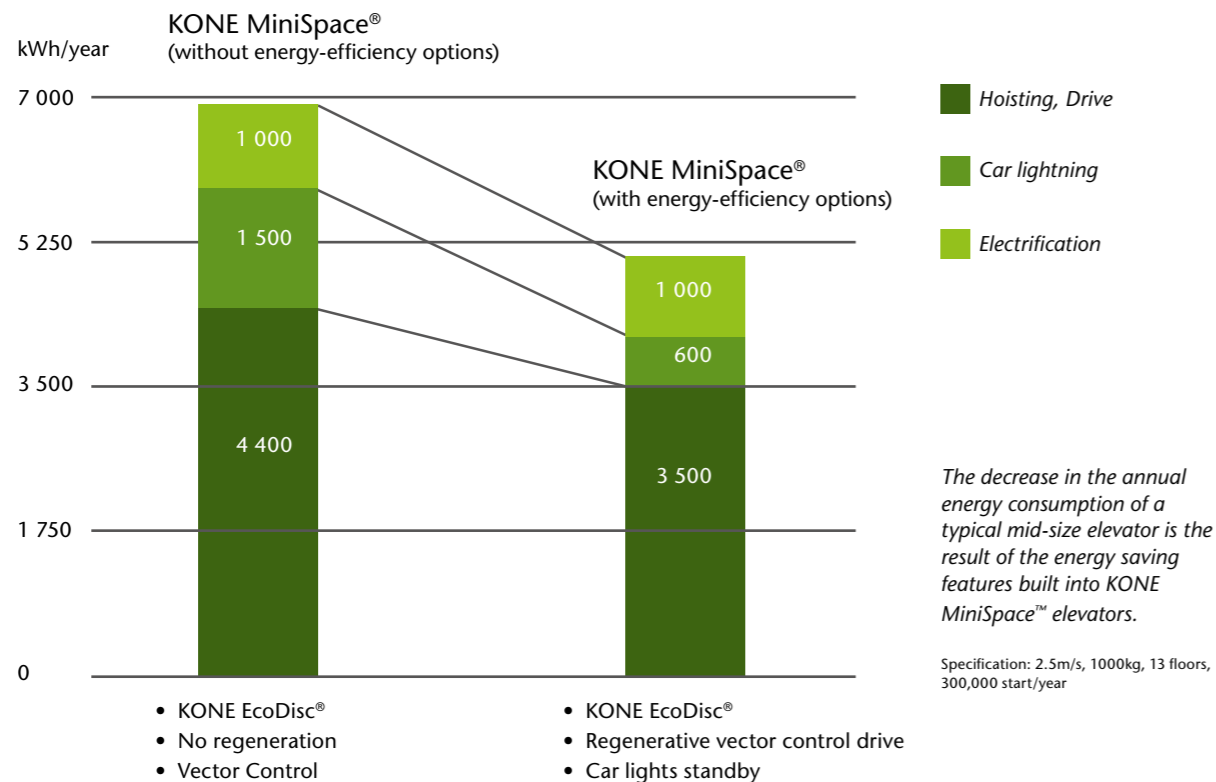

The decrease in the annual energy consumption of a typical mid-size elevator is the result of the energy saving features built into KONE MiniSpace™ elevators.



Energy-efficient lighting and stand-by solutions
A host of other options such as energy-efficient car lighting and solutions that switch car lights, fan and signalization to stand-by mode when the elevator is not in use, further reduce the energy consumption of the elevator. LED lights, for example, consume 80% less energy than halogen lights, and last ten times longer.

Dedicated enhancements for the demanding medical segment

KONE offers a wide selection of options and accessories to help you monitor, manage and maximize the performance of your people and goods flow solutions.



The OPC interface is used to deliver information on in-car flat screens. This helps to guide visitors and staff using the elevators.

Easy integration with other systems

KONE elevators and elevator management systems can be integrated with other building automation systems using open connectivity standards (OPC). In a hospital this offers significant benefits, as the different logistical and information management tasks can be seamlessly integrated and optimized between different suppliers and brands without costly customized developments.

Integrating horizontal and vertical logistics

Thanks to the OPC standards used in KONE management systems, KONE has integrated elevators with AGV (Automated Guided Vehicles) systems in many hospitals. This offers many logistical advantages, since AGVs are not limited to horizontal movement only but can also travel from floor to floor.

The AGV units automatically navigate in the hospital, delivering food, laundry, and medical supplies based on commands from the logistics system and a building map in the AGV's memory. AGVs do not collide into each other or with people as they can 'see'. AGV units can also 'speak' and ask people to please step out of the way.



Photo by Swisslog AG

AGVs are automatic guided vehicles that navigate unmanned through the hospital. When needed, the AGV calls the elevator via WLAN and OPC interface and changes the elevator to 'freight service mode'. The elevator serves the current passengers and goes to the floor where the AGV is waiting. The AGV then enters and requests a floor. Upon arrival, the AGV drives out and the elevator returns to normal mode.

KONE E-Link™ elevator monitoring and management system

KONE E-Link provides an accurate view of the transportation status, demand, performance and availability of elevators and escalators in the building. This helps you ensure that the equipment delivers the best possible performance at all times. KONE E-Link has an open interface to allow integration with other facility management systems.

- Real-time view of equipment status locally and remotely. Large building complexes or geographically remote buildings can be monitored and managed from a single location
- Traffic history playback possible for event history, security and possible legal purposes
- Faster reaction to malfunctions, possible misuse and troubleshooting
- Faster rescue of entrapped passengers
- Local and remote control of equipment, scheduled commands like lockings and change of operation mode
- Easy integration with other facility management systems in the building

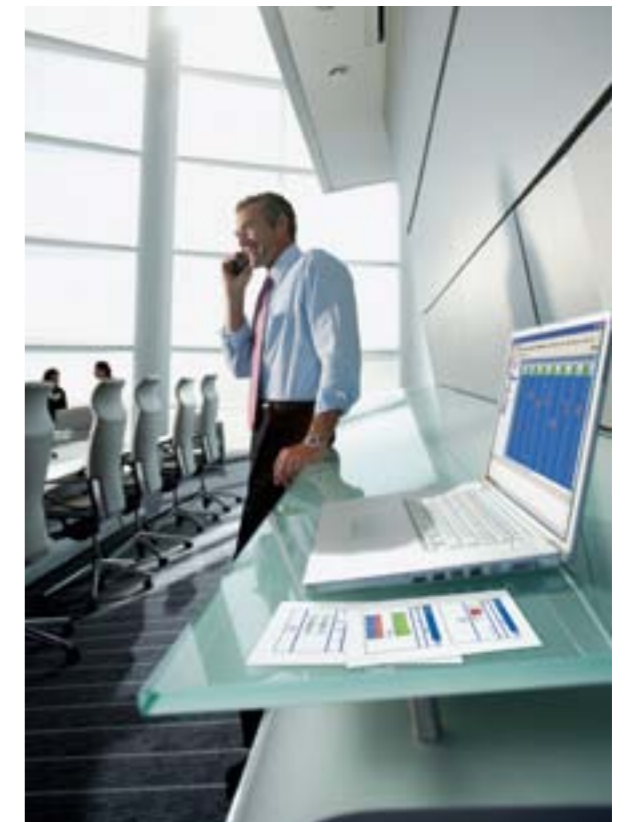

KONE Polaris™ Destination Control

The KONE Polaris Destination Control system offers two benefits for medical facilities: better traffic handling and improved passenger guidance.

- Users in the lobby select their destination floor before entering the elevator; when the elevator arrives the destination floor is already registered
- The Destination Operating Panel can work as an interactive directory showing the different wards and departments
- Conventional landing call stations and indicators can be used on other landings



The Destination Operating Panel can work as a directory showing the different wards. When the user enters the lobby, he or she selects the destination on the Destination Operating Panel. The DOP indicates which elevator will be available. When the elevator arrives, it automatically takes the visitor to the desired floor.

KONE hermetic sealing sliding doors

For conditioned rooms, KONE hermetic sealing sliding doors are the ideal solution, with low weight and very good noise reduction.

- Designed for use in operating theatres and other clean room environments
- Equipped with special rubber seals, rounded profiles and door panels covered on both sides with high pressure laminate
- Can reduce the noise level by as much as 34dB
- Provide protection against fire and X-ray radiation



Lower cost of ownership for the lifetime of the facility

KONE has long experience in complex hospital projects, from the early design stages and throughout the building's lifecycle. When designing the building, thorough people flow analysis ensures that you have the right equipment for your requirements. Comprehensive project management services support the construction phase of the project. Preventive maintenance saves costs throughout the lifetime of the equipment, and flexible modernization solutions enable you to upgrade elevators and escalators as needed.

Design

We supply more than elevators, escalators and building doors. We provide a complete People Flow™ solution, designed to serve you for the lifetime of the building. So our work begins a long time before the elevator shafts go up on the construction site. We can provide thorough analysis and simulations of the flow of patients, staff, visitors and supplies in the hospital, in order to match the capabilities of the equipment with your requirements.

Visual design of elevators in hospitals is important, not only from the aesthetics point of view, but also from functional, durability and hygienic points of view. KONE works with your design team to ensure that the people flow solution meets the requirements of the medical facility and is integrated with the architect's vision. You can choose from our wide range of KONE Design option interiors or you can create a fully custom-designed solution.

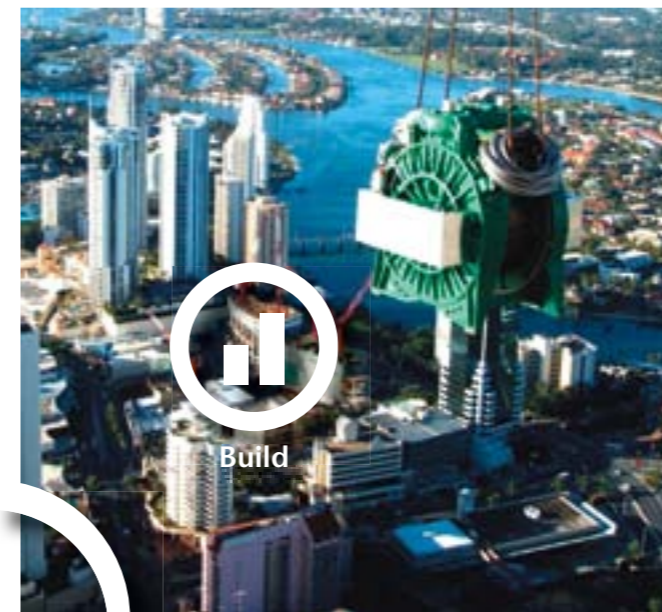

Build

KONE has been involved in many major hospital projects; a few examples can be seen on the following pages. Our experienced project management teams guarantee smooth coordination with all parties involved in the project. KONE also can supply solutions that speed up the construction process. KONE's construction time elevators enable fast and efficient vertical transportation of people and goods during the construction phase.

Once the equipment has been installed, our experts examine and evaluate its performance, ensuring that all quality requirements have been met.

Modernize

Modernizing your elevators, escalators or building doors is an investment that can pay for itself. For patients and visitors, KONE modernization solutions increase safety, convenience and accessibility. For facility managers, they minimize disruption and maximize availability. And for hospital administration, they improve energy efficiency, reduce operating costs, and make elevator life-cycle management and budgeting more predictable.

With KONE Care for Life™ services, we help you determine when and how to modernize, with a thorough assessment of the safety, accessibility, reliability, eco-efficiency and appearance of your elevators. Depending on the results of this analysis, KONE can recommend a solution ranging from small repairs to modular modernization to full replacement.



Operate and Maintain

Elevators, escalators and doors in medical facilities must function without interruption around the clock. Our trained maintenance technicians service all types of equipment, both from KONE and from other manufacturers.

KONE maintenance is based on preventive care, to solve problems before they can lead to downtime. With the KONE Remote Monitoring Service, we can keep an eye on the condition of your equipment from our KONE Customer Care Center. If the operation of the equipment deviates from normal, we dispatch a service team, with spare parts and knowledge of the problem. Often we can solve the problem before passengers have even noticed there was one.

KONE offers three maintenance solutions, KONE Care™ Standard, Plus and Premium, tailored to the different levels of requirements. You can further enhance the solution with additional services from the service portfolio.

References



Hospital de Oviedo Asturias (HUCA), Spain

When completed, HUCA will be the second largest hospital in Spain. An important consideration for the hospital when making the decision to work with KONE was the lower total cost of ownership over the lifetime of the equipment. This is achieved through the reliability of the machine-room-less KONE MonoSpace elevators, backed by KONE's comprehensive maintenance services, designed particularly for the needs of hospitals. An important component ensuring long-term reliability is KONE E-Link, which enables monitoring of the performance and availability of all elevators in the building from one location. The hospital will contain a total of 77 KONE elevators for transporting staff and visitors, patients and goods.



University Hospital, Lund, Sweden

The KONE elevators in the hospital are equipped with regenerative solutions that reduce energy consumption by 30% by recovering braking energy.

'It is the hospital's policy that everything we do must take the environmental impact into account. I am happy to state that KONE has products and solutions that meet our stringent environmental policy, while providing reliable service for patients.'

Arne Pettersson, Project Manager
University Hospital



CHU de St Etienne Hôpital Nord, France

The KONE hospital bed elevator has been specially designed to transport patients from the heliport to the emergency room in optimal conditions. For reasons of safety, it is not possible to have a machine room on the roof near the heliport, but it is urgent that patients are transported to the emergency room as quickly as possible, without exposing them to wind and rain on the roof. The KONE MonoSpace heliport elevator needs no machine room, so the roof above the shaft is flat. When the elevator is called from the heliport level, it rises through the roof of the building near the helicopter, so that the patient can be transported quickly and safely. Four types of elevators have been installed: 11 passenger elevators, 10 bed elevators, 14 service elevators, and two smaller units for transporting goods.



St. Olav's Hospital, Trondheim, Norway

In order to free staff for other duties, the hospital uses Automatic Guided Vehicles (AGVs) to deliver food throughout the building. The AGVs are integrated with the KONE elevators in the hospital. When the AGV calls the elevator via WLAN, the passenger elevator becomes a goods elevator; it disables calls and takes passengers to their floors. When it is empty, the elevator comes to the floor where the AGV is waiting and transports it to the desired floor.



KONE provides innovative and eco-efficient solutions for elevators, escalators and automatic building doors. We support our customers every step of the way; from design, manufacturing and installation to maintenance and modernization. KONE is a global leader in helping our customers manage the smooth flow of people and goods throughout their buildings. Our commitment to customers is present in all KONE solutions. This makes us a reliable partner throughout the life-cycle of the building. We challenge the conventional wisdom of the industry. We are fast, flexible, and we have a well-deserved reputation as a technology leader, with such innovations as KONE MonoSpace®, KONE MaxiSpace™, and KONE InnoTrack™. You can experience these innovations in architectural landmarks such as the Trump Tower in Chicago, the 30 St Mary Axe building in London, the Schiphol Airport in Amsterdam and the Beijing National Grand Theatre in China.

KONE employs over 32,000 dedicated experts to serve you globally and locally in over 50 countries.

KONE Corporation
www.kone.com

Dedicated to People Flow™



MANAGING THE FLOW OF PEOPLE AND GOODS IN MEDICAL BUILDINGS

KONE solutions for medical facilities

Elevator solutions for all medical applications

Elevators are essential for ensuring the smooth flow of people and goods in the hospital. KONE provides a full range of elevator solutions, for supplies and equipment, staff, visitors and patients, whether they are coming in the front door or landing on the roof. When designing solutions for the medical environment, our criteria are extreme reliability, safety and energy-efficiency, which lower the cost of ownership and the environmental impact. In hospital environments special attention is paid to hygiene. Materials have been carefully selected to be aesthetically pleasing and easy to clean.

KONE bed elevators

KONE bed elevators are designed especially for hospital environments, offering the following features:

- **Specialized car dimensions** – to accommodate the bed and medical equipment, with wide-opening doors and deep car size
- **Smooth loading and unloading** – precise leveling for easy entry of wheelchairs, beds and patients
- **Emergency/priority/remote calls** – for immediate availability during emergency situations
- **Quiet, smooth operation** – to prevent disturbance to traveling patients and in rooms near the elevator shaft
- **Flush-mounted operating panels** to avoid collisions with medical equipment
- **Indirect, non-glare lighting** and clear indicators to improve visibility and provide guidance for users



KONE passenger elevators

KONE passenger elevators are designed to transport visitors and staff smoothly and energy-efficiently.

- **Space efficiency** - maximum car sizes with minimum shaft dimensions. Increases passengers' convenience while saving construction costs
- **Machine-room-less** – enables elevator to serve the top floor – or even the roof – without a machine room on the roof of the hospital
- **Design** – wide selection of design alternatives to match the buildings architecture
- **Wide duty range** – to satisfy the people flow requirements of any hospital

KONE service elevators

To move heavy loads, you need an elevator that is designed specifically for that purpose:

- **Fast and durable hoisting** to cope with rough treatment
- **A smooth ride** to handle fragile loads
- **Accurate leveling** for easy loading and unloading
- **Full-width doors** that maximize use of space in the car

KONE elevator types and duty ranges for medical applications

	Nominal load		Travel (m)	Speed (m/s)
	(persons)	(kg)		
Bed elevators	17-53	1000-5000	up to 70	1.0-2.0
Service elevators	17-53	1000-5000	up to 23	0.6-1.0
Passenger elevators	8-17/21	630-1275/1600	40-80	1.0-3.5

For more detailed information about available car and shaft sizes, see separate planning information or contact your KONE sales representative.

KONE helipad elevators

In urban areas, often the best way to access the hospital in an emergency is by helicopter. Because of the safety areas around the helipad, the elevators to the roof have traditionally been located relatively far from landing spot, so valuable time is lost and the patient may be exposed to open air and rough weather. The KONE MonoSpace® elevator does not need a machine room on top of the shaft, so the elevator car can literally come through the hospital roof close to the helicopter as soon as it has landed. Several KONE helipad elevators are in operation in hospitals around the world.



As soon as the helicopter has landed, the KONE MonoSpace® elevator rises through the roof, providing the fastest way to take passengers into the hospital.

