

Dedicated to People Flow™



MACHINE-ROOM-LESS FREIGHT AND SERVICE ELEVATOR

KONE TranSys™



More hoisting power, lower energy consumption

The power to lift up to 5000kg
 The KONE TranSys™ freight elevator solution is based on the machine room-less KONE MonoSpace® platform. It incorporates the highly reliable and eco-efficient KONE EcoDisc® hoisting machine for exceptional power and performance.

- This machine delivers more hoisting power with less energy:**
- It consumes 70% less energy than a hydraulic drive
 - Over the lifetime of the equipment, the energy savings can amount to more than the original cost of the elevator
 - No oil is required, reducing fire risk and environmental impact.

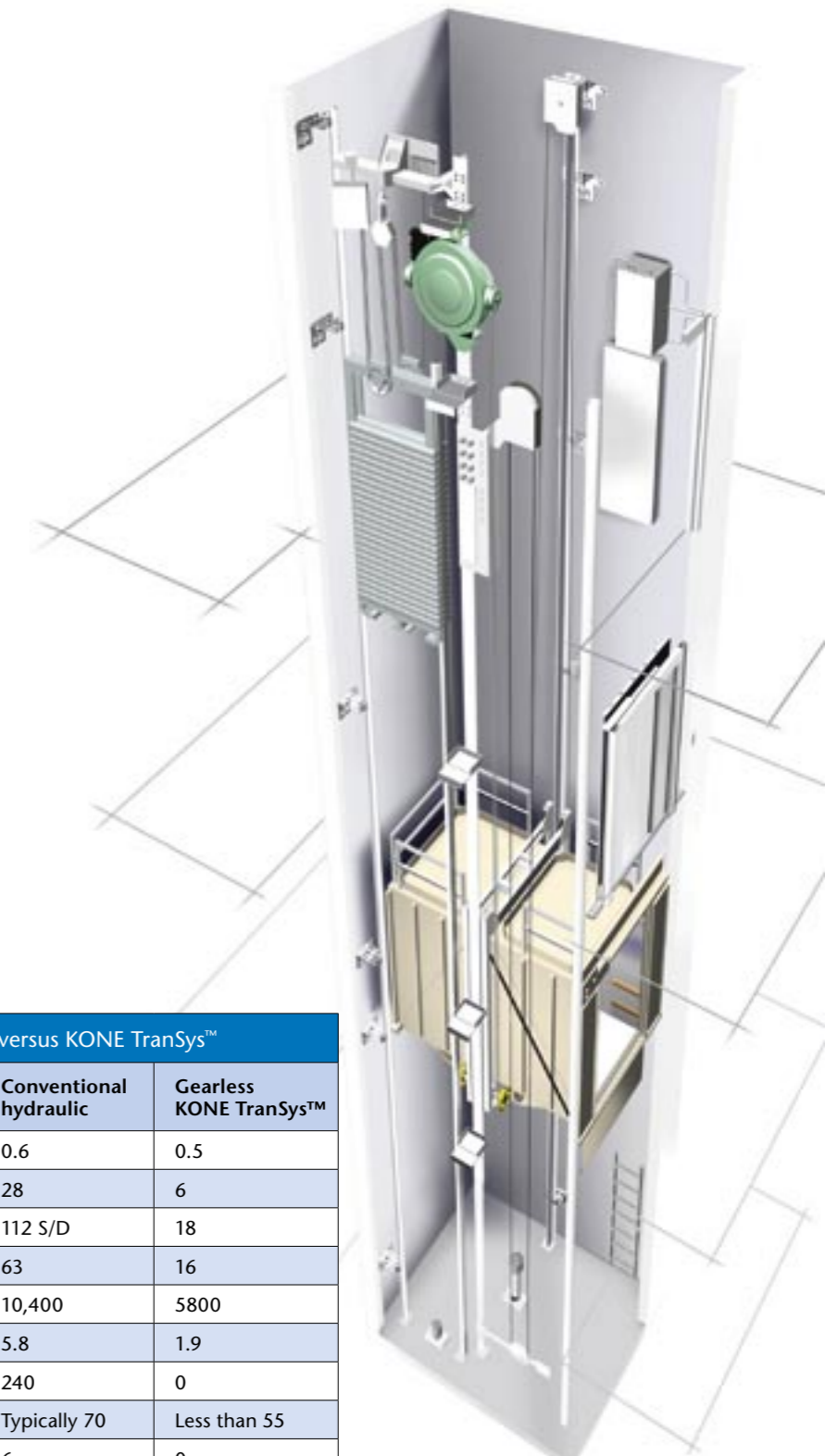

Moving freight and heavy loads just got easier

To move freight and heavy loads, you need an elevator that is designed specifically for that purpose:

- Fast and durable hoisting to cope with rough treatment
- A smooth ride to handle fragile loads
- Levelling accuracy for easy loading and unloading
- Full-width doors that maximize the usage of space in the car
- A selection of signalization and interior designs for an easy match to the building's interior.

The powerful and high-performance KONE TranSys™ freight and service elevator solution is ideal for a multitude of demanding vertical transportation tasks in a variety of buildings: supermarkets, shopping malls, airports, warehouses, hospitals, hotels, industrial plants and offices.

This elevator is fully customizable and combines speed, power and premium quality designs.

A typical 2000 kg hydraulic elevator versus KONE TranSys™		
Load 2000kg	Conventional hydraulic	Gearless KONE TranSys™
Speed (m/s)	0.6	0.5
Motor power (kW)	28	6
Starting current (A)	112 S/D	18
Main fuse size (A)	63	16
Power consumption (kWh) > 100,000 starts/year	10,400	5800
Thermal losses (kW)	5.8	1.9
Oil requirements (L)	240	0
Noise (dBA)*	Typically 70	Less than 55
Machine room (m²)	6	0

* Measured 1 m from machine.

Outstanding power and performance

Exceptionally space-efficient

The KONE TranSys™ freight elevator needs no machine-room at all. This means:

- Easier positioning of the elevator in the building
- Reduced building construction time and costs
- More efficient, safer elevator installation processes
- Up to 30m³ extra building space that can be used more profitably.

Reliable, high performance

The KONE TranSys freight and service elevator solution provides reliable operation, outstanding traffic performance and a smooth ride at up to 1.6 meters per second. The ride quality is the result of the motor's low rotational speeds. The low friction, gearless construction of the KONE EcoDisc® hoist reduces wear, so it increases the reliability and durability of the machine.



Easy loading and unloading

Powered by the gearless KONE EcoDisc® machine, the KONE TranSys freight and service elevator solution features quiet operation, smooth running to protect fragile loads and ± 5 mm leveling accuracy to make loading and unloading easier.

Wide load range

The KONE TranSys elevator is available in different car sizes to transport freight and other heavy loads. With a maximum load capacity of 5000 kg, it can meet virtually every transportation requirement in a variety of building types.

Main specifications	
Load capacity	1000 - 5000 kg/13 - 66 persons
Speed	0.5 - 1.6 m/s
Max. travel	40 m up to 4000 kg, 23m up to 5000kg
No. of floors	12, also applicable for TTC
Persons	13 - 66
Group size	Max. 4/group
Hoisting machine	Gearless KONE EcoDisc®
Doors	Automatic center opening
Car door height	up to 2400 cm
Code compliance	EU directive 95/16; EN81-1:1998 Optional EN81-70, EN81-73 and EN81-71



Durable design

The KONE TranSys™ cars are built for the job. The car is finished in stainless or powder-painted steel, protected by buffer rails, and equipped with direct, fluorescent lighting. A second car operating panel is optional and combined with a 400 mm minimum floor-to-floor distance to suit the through-car application.

With a wide selection of wall, floor and landing door materials, the elevator can be seamlessly integrated into the building's interior.

Extra wide doors

The KONE TranSys elevator is equipped with full-width, center opening doors, which retract fully for the easy movement of passengers and goods. Further door area protection includes a curtain of light or 3D passenger detection. The strong double skin door panels are finished in stainless, powder-painted steel or zinc coated steel.

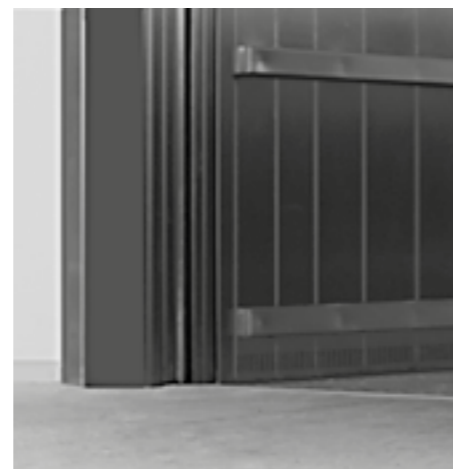

A multi-purpose elevator

This fast yet powerful elevator can even be used as a passenger elevator in shopping centres and airports where large elevator cars and fast speeds ensure uninterrupted people flow throughout the building.

KONE Vehicle™ elevator

The KONE TranSys freight and service elevator is even suitable for vehicle transportation from underground or rooftop car parks where space is at a premium.

Its main features include:

- Machine-room-less technology that allows for extra rooftop space
- Faster ride compared to hydraulic elevators
- Energy saving due to gearless hoisting technology
- Patented lightweight floor. Saves approx. 2000 kg in a typical 3000 x 6000 mm car compared to a conventional floor
- Full car width doors
- Easy elevator call with a separate landing call station on a raised pedestal
- KONE 3D passenger detector opens the elevator doors as you approach and keeps them open as you enter or exit

KONE TranSys™ signalization

Select from a wide range of durable and user-friendly elevator signalization series

<p>KSS 130</p>  <p>Vandal resistant signalization (EN81-70 compatible)</p> <p>Faceplate finishing: Scottish Quad, textured stainless steel and Asturias Satin brushed stainless steel</p>	<p>KSS 305</p>  <p>Faceplate finishing: Coated metal (R1), Monterrey Silver</p>	<p>KSS 420</p>  <p>Faceplate finishing: Asturias Satin brushed stainless steel</p>	<p>KSS 470</p>  <p>Faceplate finishing: Asturias Satin brushed stainless steel</p>	<p>KSS 670</p>  <p>Faceplate finishing: Asturias Satin brushed stainless steel</p>
--	--	---	--	---

Ceiling

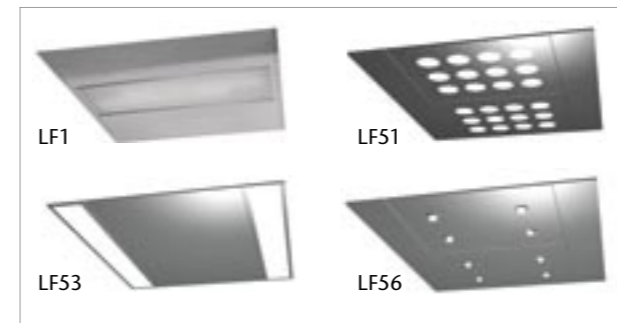

Mirrors

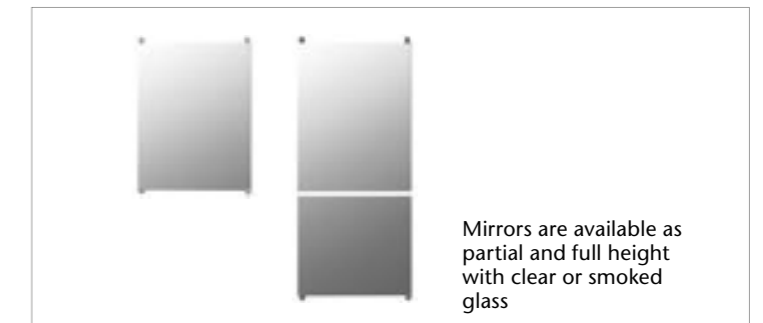

Wall material

Stove enamelled

Ochre Yellow RAL 1024	Pastel Blue RAL 5024	Pale Green RAL 6021

Tele Grey RAL 7047 Grey White RAL 9002

Zinc coated steel (Z) and powder coated Grey (P) finishes are also available.

Stainless Steel

Asturias Satin F	Flemish Linen M	Scottish Quad K

KES 600 / KES 800 door finishes

Stainless Steel

Asturias Satin F	Flemish Linen M	Scottish Quad K	Zinc Coated Z

Powder painted P

Car buffer rails

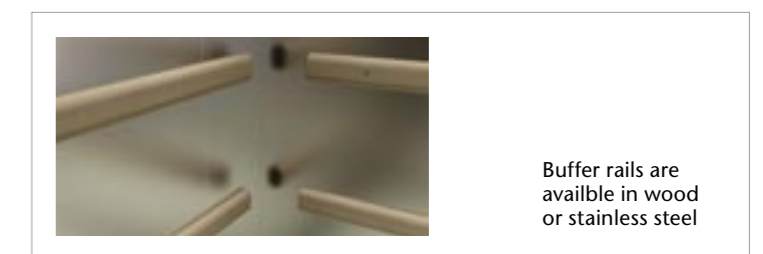

Floor material

Rubber

Aspen White(RC8)	Detroit Grey RC5	Dayton Grey RC9

Stainless Steel

Chequered steel plate 3mm ST	Tear plate 3mm SS	Tear plate aluminium AL

Aluminium

Handrails

HR41

HR41 Tube

HR41 Tube with corner module: Asturias Satin (F) Murano Mirror (H)	HR41R (EN81-70) Tube with rounded ends: Asturias Satin (F) Murano Mirror (H)	HR41TR (EN81-70) Tube with corner module and rounded ends: Asturias Satin (F) Murano Mirror (H)

Planning data

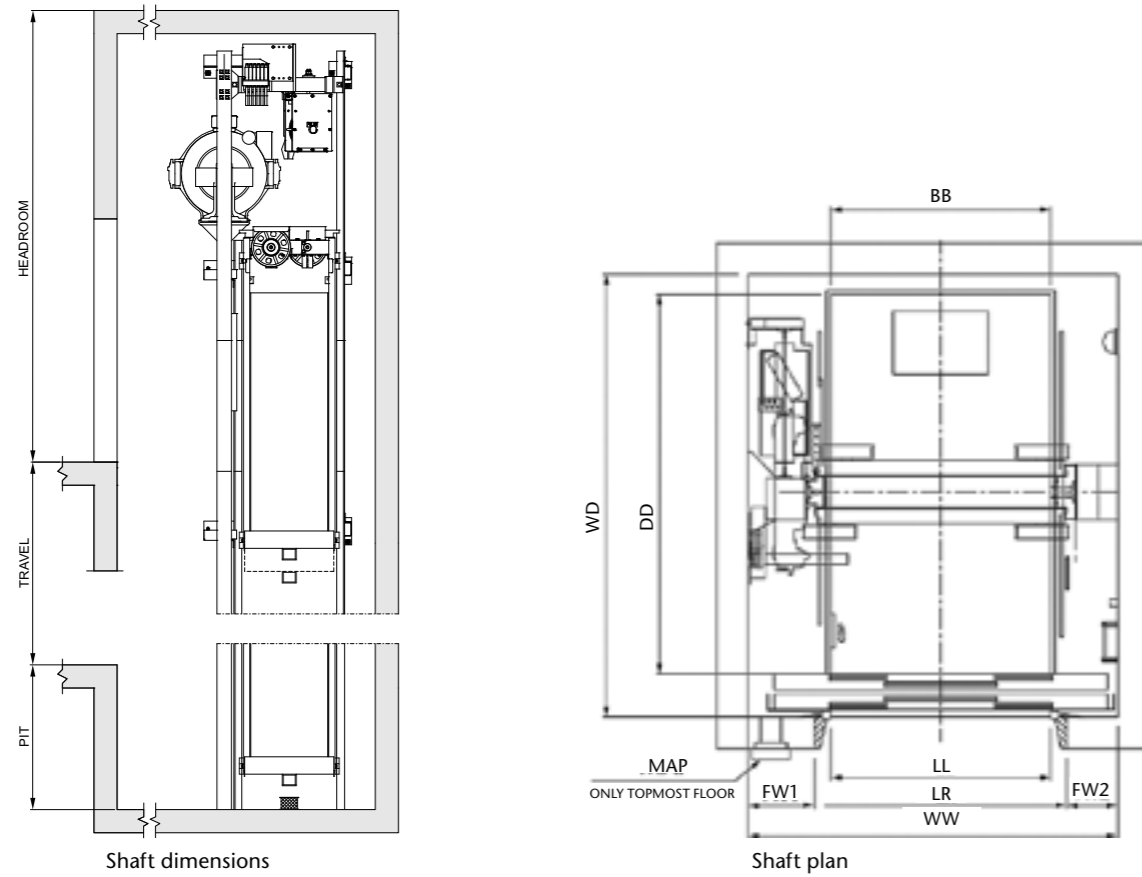

Elevators for freight, typical car and shaft sizes						
Max. load (kg)	Speed (m/s)	Car size (mm)	Car type*	Shaft width (mm)	Shaft depth (mm)	Door width (mm)
1000	0.5	1100 x 2000	SEC	1900	2450	1000
1000	0.5	1000 x 2000	TTC	1800	2700	900
1275	0.5	1200 x 2300	SEC	2100	2750	1100
1275	0.5	1200 x 2200	TTC	2100	2950	1100
1600	0.5	1400 x 2400	SEC	2350	2800	1400
1600	0.5	1400 x 2400	TTC	2350	2950	1400
2000	0.5	1500 x 2700	SEC	2500	3100	1500
2500	1.6	1800 x 2700	SEC	3000	3300	1400
2500	1.6	1800 x 2700	TTC	3000	3300	1400
3000	1.6	2000 x 2700	SEC	3250	3150	1800
3000	1.6	2000 x 2700	TTC	3250	3400	1800
4000	1.0	2100 x 3400	SEC	3250	3850	1800
4000	1.0	2100 x 3400	TTC	3250	4000	1800
5000	0.5	2500 x 3500	SEC	3650	3950	2200
5000	0.5	2400 x 3500	TTC	3650	4200	2100

* Car type: Single entry car (SEC) and through type car (TTC)

Control system features

System features	Availability
KONE Remote Monitoring with GSM connection	○
EN81-71, Vandal resistant lifts, category 1	○
EN81-73, Behaviour of lifts in the event of fire	○
KONE E-link	○
Automatic evacuation to nearest landing (EBD A)	○

Eco-efficiency features	
Regenerative drive	○*
Fluorescent car lighting	●
Car light standby (OCL A)	○
Ventilation standby (OCV A)	○
Signalization dimming	●
Drive standby	○*
Corridor illuminating control (CIC)	○

Accessibility features	
EN81-70, Accessibility to lifts for persons including persons with disability	○
Curtain of light (COL)	○
3D passenger detector	○
Lift announcer (ACU)	○
Door open with extended door time (DOE B)	○
Accurate leveling doors open (ACL/B)	○

Security features	
Locking of car calls (LOC)	○
Priority call in car (PRC)	○

* Please consult your KONE sales professional

Option ○
Built in ●



KONE provides innovative and eco-efficient solutions for elevators, escalators and automatic building doors. We support our customers every step of the way; from design, manufacturing and installation to maintenance and modernization. KONE is a global leader in helping our customers manage the smooth flow of people and goods throughout their buildings.

Our commitment to customers is present in all KONE solutions. This makes us a reliable partner throughout the life-cycle of the building. We challenge the conventional wisdom of the industry. We are fast, flexible, and we have a well-deserved reputation as a technology leader, with such innovations as KONE MonoSpace®, KONE MaxiSpace™, and KONE InnoTrack™. You can experience these innovations in architectural landmarks such as the Trump Tower in Chicago, the 30 St Mary Axe building in London, the Schiphol Airport in Amsterdam and the Beijing National Grand Theatre in China.

KONE employs over 32,500 dedicated experts to serve you in over 50 countries.

KONE Corporation
www.kone.com