

Dedicated to People Flow™



ELEGANT SOLUTION FOR MAXIMUM RETAIL EXPERIENCE

KONE TravelMaster™ 110 escalator

To increase sales...



Solution tailored for retail use

Escalators play a vital role in transporting customers in any retail centre. They smoothly connect different areas into one uninterrupted shopping experience, providing easy access everywhere from car parks to shop floors.

Better people flow means better cash flow

Retail centres with their needs vary, while effective people flow is always important.

Convenience and efficiency are paramount in moving customers. This means solutions that are inviting and functional to the end user and add value to the property.

Retail centres offer elegance and comfort to their customers. Escalators should follow suit with aesthetics that match the building. Attractive designs and colours create a pleasant atmosphere, as does equipment that complements the environment.

... you need to bring the customers to you

Quality, reliability and return on investment

Retail centres need durable and reliable solutions to ensure continuous revenue support and return on investment. Equally important is safety, especially for children, the elderly and the infirm.

Another requirement is optimal lifecycle costs. Building owners need escalators that are cost-effective and reliable.



KONE TravelMaster™ 110 – Your ideal escalator



KONE is one of the leading companies in the elevator and escalator business, offering its customers:

- Elevators with exceptional power and performance – some without machine-rooms – that can be seamlessly integrated into buildings
- Reliable and elegant escalators to match customers' needs, from retail to transit applications, and with high levels of cost-effectiveness and performance
- Modernisation and full replacement solutions to upgrade and maximise the potential of the product
- Comprehensive maintenance solutions for the entire lifecycle of the product
- Spare parts available globally within 24 hours

KONE offers benefits:

Time and cost savings

Highly reliable products with a low total cost of ownership with an emphasis on simple maintenance and quick repairs to save on costly downtime.

Lower additional building and planning costs

Easier planning and more flexibility in both current and future development. KONE aims to reduce all building and planning time, as well as costs, making the whole process trouble-free.

Cost-effective, environmentally friendly operation

KONE solutions are among the industry's most environmentally friendly with energy saving operation and environmentally-friendly materials.

Maximum performance and availability

Reliable products with maximum availability that offer effective people flow solutions from an experienced, reliable partner.

Optimum maintenance

After a smooth, fast and safe installation, KONE offers maintenance tailored to suit the building usage and maximise the performance of the equipment.

Unsurpassed know-how

KONE has the know-how to evaluate the most economic and feasible solution for each specific project and then implement trouble-free project management from start to finish. KONE Site Absolutes are an easy site requirement guide for the builder.

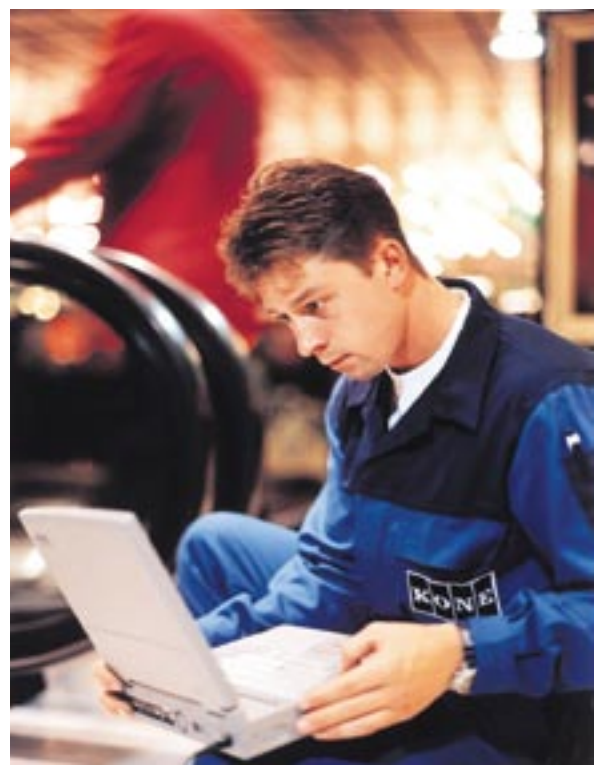



KONE TravelMaster™ 110 means better people flow

- Effective and comfortable transportation between floors brings business to you
- Great window-shopping opportunity
- Guiding customers with an inviting design

KONE TravelMaster™ 110 is tailored for retail environment

- Efficient and smooth ride to maximise the shopping experience
- Elegant design that complement the architecture of the building
- New visual options that increase aesthetic value
- Timeless appearance and compact dimensions make KONE TravelMaster™ 110 easy to fit into most retail environment

KONE TravelMaster™ 110 is a future proof investment

- Focus on lifecycle costs and modernisation possibilities ensures a sound return on investment
- With KONE, you have a global partner that can offer 24 hours call centres and matching spare parts availability

KONE TravelMaster™ 110 escalator

– technically outstanding



Lubrication free chain

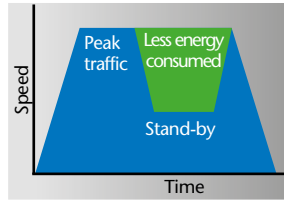

Stand-by speed

Ecological design for efficiency

- Energy efficient and user-friendly stand-by speed to enhance energy effectiveness
- Absolute ecological and fire safety with lubrication free chain
- Optional lubrication free chain
- Advanced components to give a lifetime of reliable performance
- KONE expertise and know how in maintenance and service

Tailored for retail environment

- Elegant and timeless design to welcome the customers
- Efficient and smooth ride to maximize the shopping experience
- Numerous lighting options that guide the customers and enhance atmosphere
- Effective and functional link between floors for better people flow
- Compact dimensions for easy installation and fit into most retail environment



LED skirt lighting

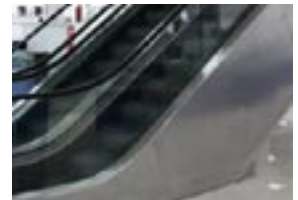

Stainless steel cladding



Elegant and timeless frontplate



Hot dipped galvanised truss provides full corrosion protection



Diagnostic display

Uncompromising reliability

- Full outdoor capabilities in uncompromising conditions
- Operation even in compromising conditions through optional outdoor weatherproofing
- Based on KONE technology that will last

Safety and effectiveness

- Maximum availability through advanced control system
- Fast and effective trouble-shooting through built-in diagnostics
- Reliable KONE maintenance offers an efficient and quick response to possible problems, minimising downtime
- Extensive safety and monitoring options
- Thicker material uses for skirt panel and decking which is standard offering
- Enhance safety for user



3mm thick skirt panel enhance user safety



Skirt brush deflector



Anti climb barrier



New EN115 compliance

KONE TravelMaster™ 110 escalator

Basic data	
Inclination	30° or 35°
Level Steps	2/2 or 3/3
Maximum vertical rise	Up to 9.5m
Step width	600mm, 800mm, 1000mm
Balustrade	Clear tempered glass
Balustrade height	900mm, 1000mm or 1100mm
Speed	0.5m/s
Electrication	EN115

Dimension unit (mm)			
Step type	S1000	S800	S600
W1: Width of step	1000	800	600
W2: Handrail centre distance	1262	1064	866
W3: Hoisting holes distance	1360	1160	960
W4: Width of truss	1510	1310	1110
W5: Width of escalator	1547	1347	1147
W6: Width of pit	1650	1450	1250

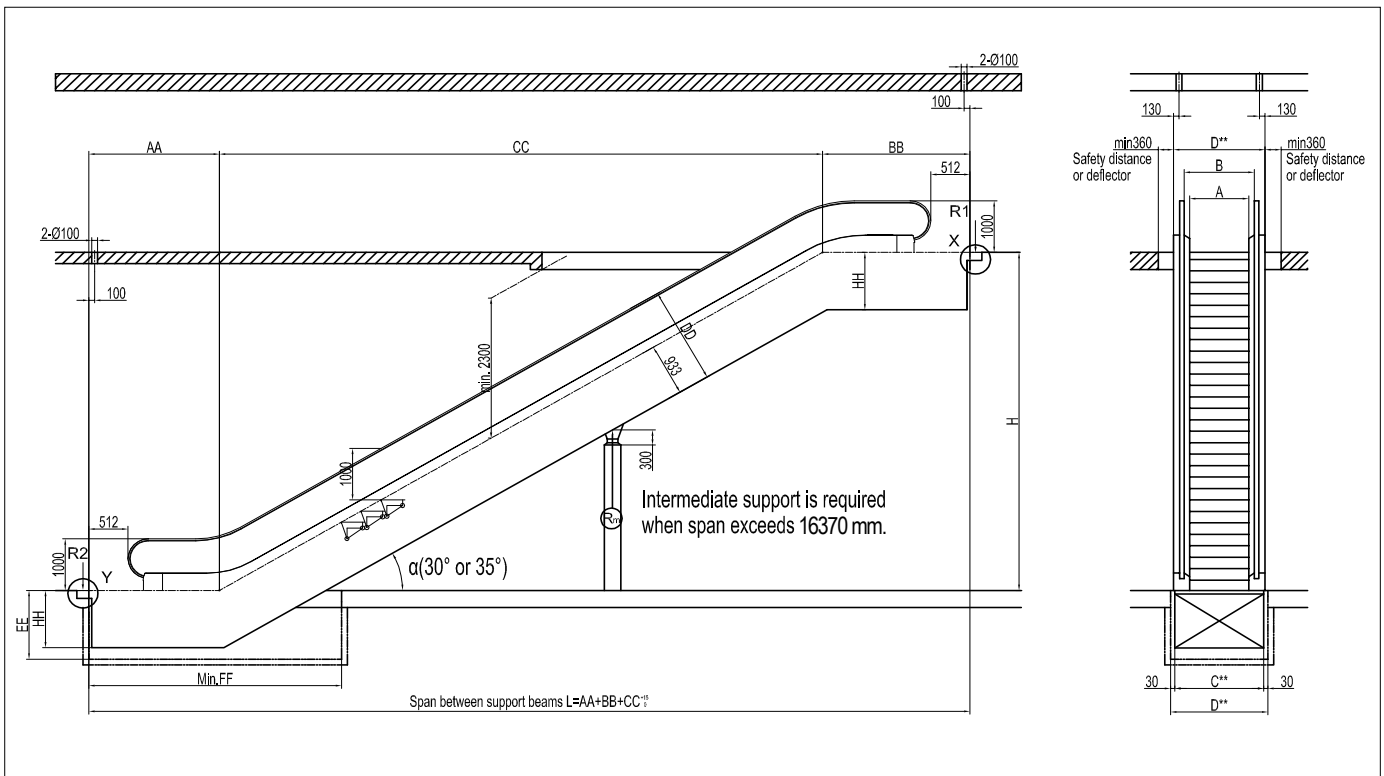

Type	Step width	AA	BB	CC	DD	EE*	FF	GG	HH
30-2	1000/800	2215	2500	1.7321H	667	667	4285	780	1000
	600	2215	3000	1.7321H	667	1167	4285	780	1000
35-2	1000/800	2250	2560	1.4281H	667	667	4080	737	1000
	600	2250	3060	1.4281H	667	1167	4080	737	1000
30-3	1000/800	2615	3034	1.7321H	667	667	4685	780	1300
	600	2615	3534	1.7321H	667	1167	4685	780	1300
35-3	1000/800	2650	2960	1.4281H	667	667	4480	737	1000
	600	2650	3460	1.4281H	667	1167	4480	737	1000

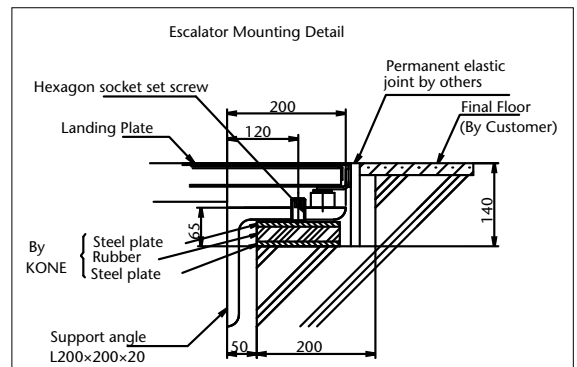

* This dimension is based on 900 mm balustrade height.



KONE provides innovative and eco-efficient solutions for elevators, escalators and automatic building doors. We support our customers every step of the way; from design, manufacturing and installation to maintenance and modernization. KONE is a global leader in helping our customers manage the smooth flow of people and goods throughout their buildings.

Our commitment to customers is present in all KONE solutions. This makes us a reliable partner throughout the life-cycle of the building. We challenge the conventional wisdom of the industry. We are fast, flexible, and we have a well-deserved reputation as a technology leader, with such innovations as KONE MonoSpace®, KONE MaxiSpace™, and KONE InnoTrack™. You can experience these innovations in architectural landmarks such as the Trump Tower in Chicago, the 30 St Mary Axe building in London, the Schiphol Airport in Amsterdam and the Beijing National Grand Theatre in China.

KONE employs over 30,000 dedicated experts to serve you globally and locally in 49 countries.

KONE Corporation
www.kone.com