

The heart of your building™



KONE Alta™

The high rise elevator system for the 21st century



KONE innovation for high altitudes

KONE's rise to a leading global elevator and escalator company derives from a succession of industry firsts and technological innovations. Each new achievement has lifted us higher, bringing our visions of ultimate vertical transportation systems closer to reality.

KONE Alta™ began as such a vision. Drawing upon the global resources of the recognised innovator. Raising elevator technology to new heights.

KONE Alta™ is the ultimate high-performance elevator system dedicated the world's tallest buildings, offering a unique combination of intelligence, speed, ride comfort, reliability, safety, and space and energy efficiency.

The KONE Alta™ blends advanced technology with design flexibility, backed up by our global project planning and implementation capabilities.

K O N E A l t a TM

The maximum load/speed capabilities of the Alta:

Duty	Load		Speed	
	kg	lb	m/s	fpm
Single-deck	2 000	4 400	17	3 400
Double-deck	5 000	11 000	10	2 000
Freight	10 000	22 000	4	800



K O N E A l t a TM

One elevator technology throughout the building

The KONE Alta™ completes the range of our EcoSystem™ elevators. KONE is the first elevator company to offer high-quality gearless elevators for all types of buildings. In tall buildings, this means 100% consistency throughout the building – same-generation elevator technology for low-, mid- and high-rise applications alike.



Online safety, security and operational supervision of elevators and escalators



Car interiors and landing elements can be tailored for each individual project



Energy- and space-efficient EcoDisc® hoisting machines

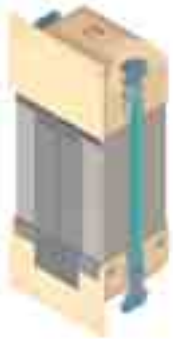

Silent Car™ technology for ultimate ride comfort, streamlined for very high speeds

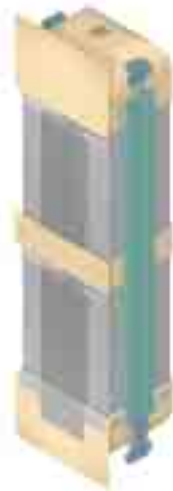

Single- and double-decker cars

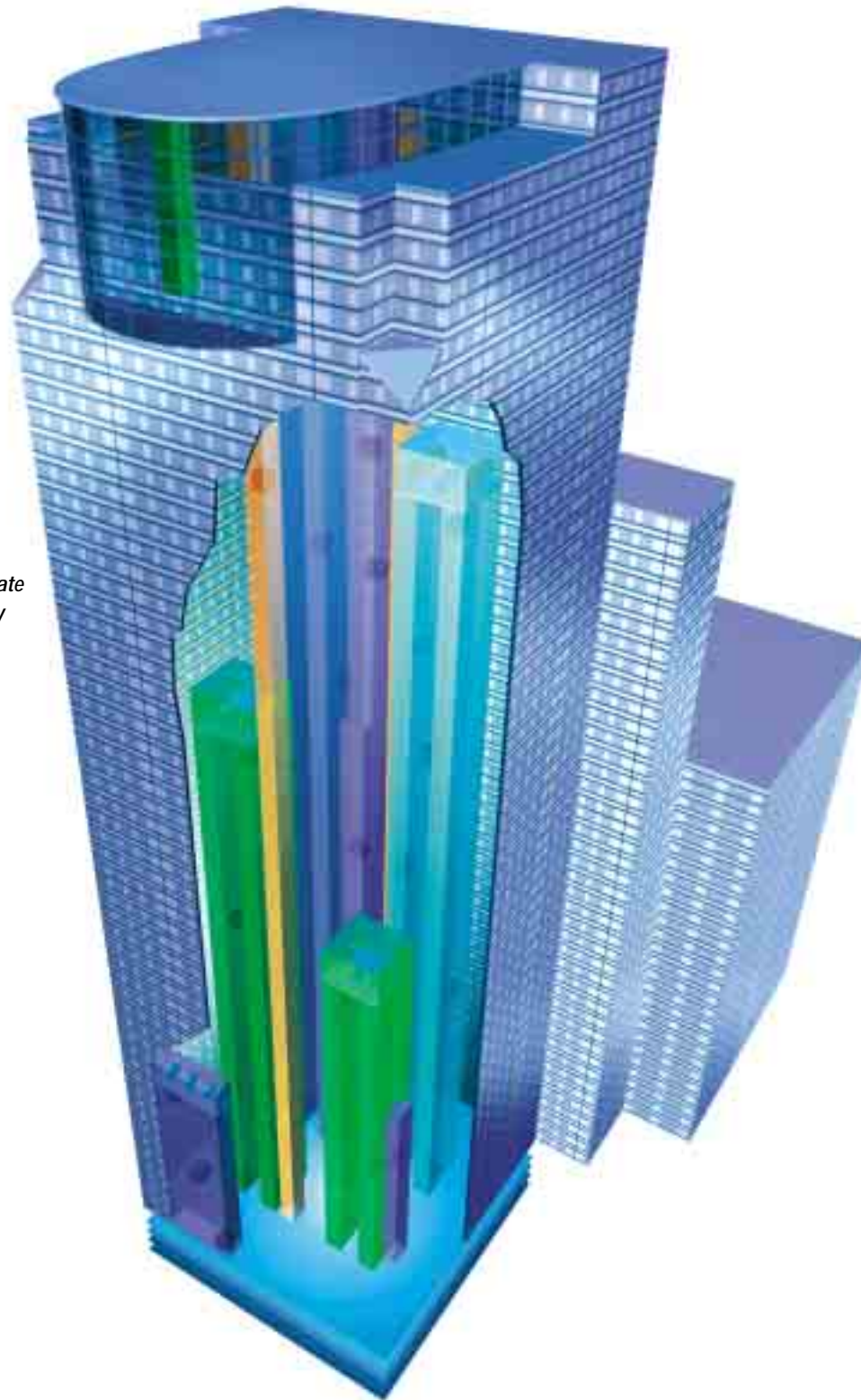
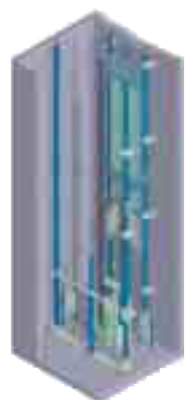

KONE Alta™ elevator system features advanced sub-systems and components, conceived, developed and engineered to meet the highest standards required for building heights of up to 500 meters (1 600 ft).

Power to soar, performance to admire

KONE Alta™ high performance specification features the new generation EcoDisc®, hoisting machines based on PMSM (Permanent Magnet Synchronous Motor) technology to replace conventional AC gearless machines. The advanced group control system takes advantage of the vast memory capacity and processing speed of modern computers. The specification is enhanced by a PMSM-powered door system and expertly designed single- and double-deck elevator cars that minimize noise and vibration, ensuring outstanding ride comfort.

The sum of the parts equals state-of-the-art technology, a truly extraordinary elevator system.



K O N E A l t a TM



K O N E A l t a TM

KONE Alta™ combines design and technology

The Alta™ system sets a new benchmark in elevating major buildings, combining advanced technology with architectural innovation.

KONE Alta™ accommodates a broad range of decorative treatments to allow extension of chosen architectural design themes into the elevators.



The powerful double-rotor EcoDisc® machines are amazingly efficient and compact. They feature twice the power-to-weight ratio of equivalent conventional AC gearless machines.

Minimum passenger waiting and flight times are ensured by the Traffic Master 9900 GA control system. Its Genetic Algorithm features multi-target-optimizing capability. Artificial Intelligence and Fuzzy Logic are applied to perform support tasks.

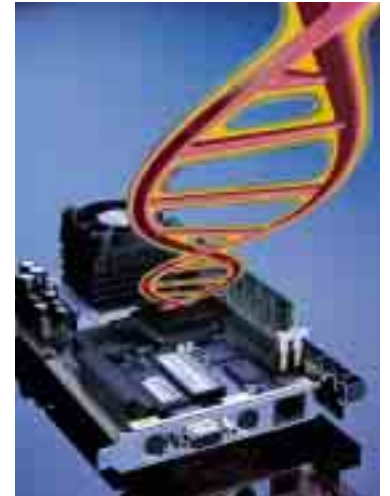

KONE Alta™ innovations include a ride that is 'tuned' for comfort. Vibrations, sway and noise are minimized for impressively smooth travel to and from each stop.



The KONE Alta™ door system contributes to user comfort and convenience. It provides fast and intelligent operation for maximum traffic performance while also serving as architectural elements both in the cars and on landings.

Optional information screens in the cars may be used display elevator, building or advertising messages to tenants and visitors.

KONE E-link monitoring system links all elevators and escalators to the facility management system of the building.



The heart of a giant

The high speed KONE Alta™ elevators are powered by double-rotor versions of the KONE EcoDisc® hoisting machine coupled with an optimized vector-controlled V³F drive system. Since their launch in 1996, the superior characteristics of these revolutionary synchronous, permanent magnet power units have been proven in thousands of installations worldwide. The high-speed EcoDisc® units offer up to 35% better energy efficiency than conventional AC or DC gearless machines while delivering outstanding performance and an extraordinarily smooth and quiet ride.



The largest EcoDisc® MX 100 machine can generate a top speed of 17 meters a second (3 400 fpm). Thanks to its unique axial design its weight is still only half that of conventional AC or DC units.

A low-angle, upward-looking photograph of several modern skyscrapers at dusk or night. The buildings are illuminated with warm yellow and white lights, contrasting against the deep blue twilight sky. The perspective creates a sense of height and architectural grandeur. The text 'KONE Alta™' is centered in the middle of the image.

K O N E A l t a [™]

KONE EcoDisc® machines ...

..are compact and feature a very high power-to-weight ratio. They offer flexibility for machine room layouts and save up to 30 tons of weight (high-speed 8-car group), reducing structural support requirements.

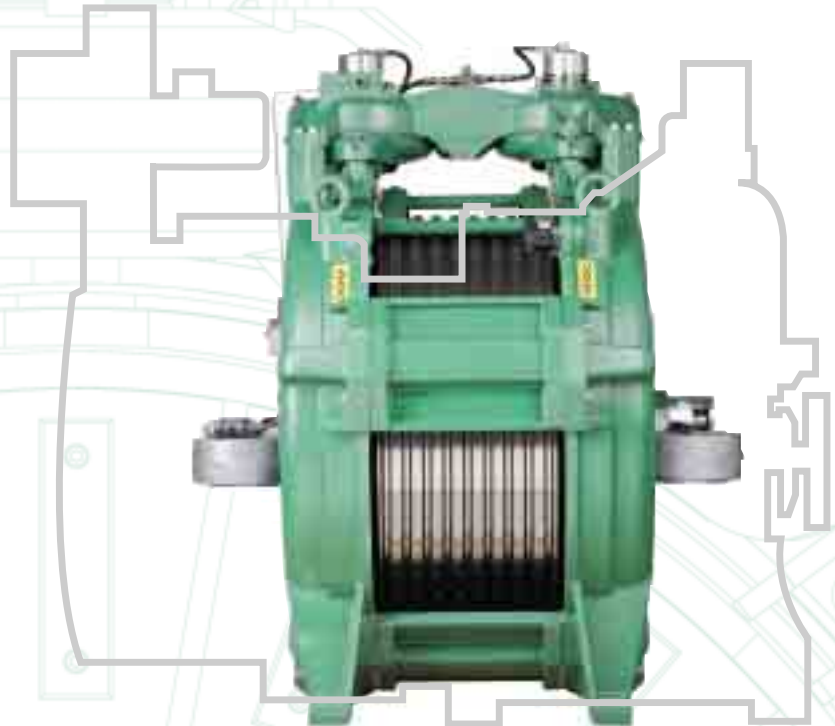

Compact EcoDisc® dimensions save space and accelerates installation

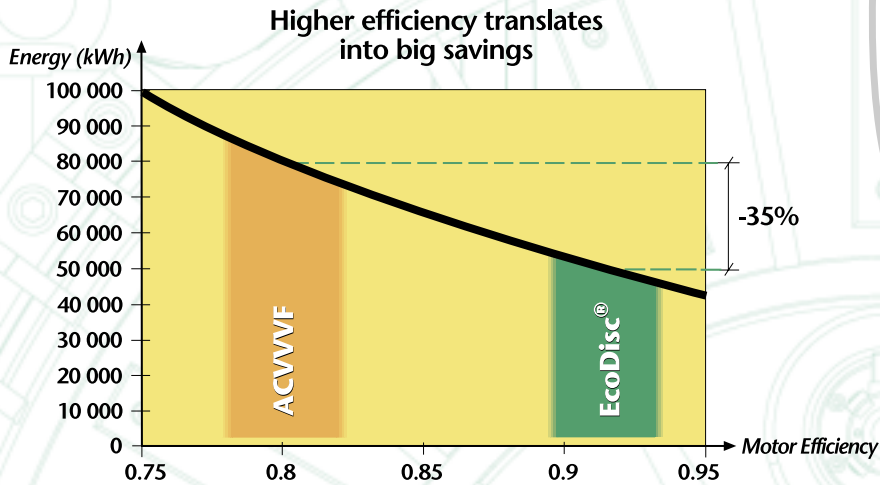

Annual Energy Consumption (kWh)
8-car group, 8m/s (1 600 fpm)

ACVVVF	EcoDisc®	Savings
640 000	416 000	224 000 (-35%)

The KONE Alta™ single-wrap roping arrangement not only helps achieve a higher standard of ride comfort, it also extends rope life to two to three times over the traditional double-wrap alternative.

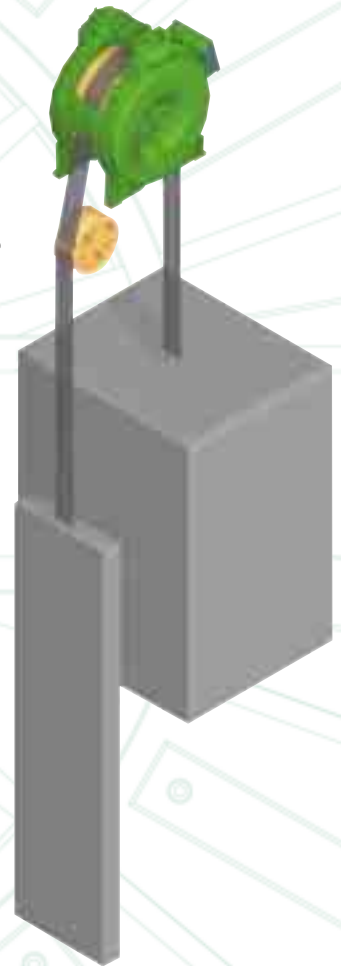

Elimination of slip and magnetizing losses, 92% efficiency and 0.95 power factor combine to reduce energy and make a significant contribution towards a building's environmental performance. Low thermal losses minimize the need for machine room air conditioning. Low peak current means lower-duty risers and fuses, and reduced cost of emergency power equipment. All these shrink the up-front investment, and also join the direct and indirect long-term advantages that all KONE elevators 'Powered by EcoDisc®' provides.



Permanent magnets are a fundamental feature of all EcoDisc® motors.

Symphony of movement

KONE Traffic Master 9900 GA group control system is the nerve center working within a high-speed serial communication network to create an interactive symphony of movement throughout the building.

The system derives its superior traffic performance from the parallel use of several 'soft computing' methods. The dispatch function is based on the advanced, high-speed Genetic Algorithm (GA) which selects the best possible routing of the elevators for the most effective passenger service in all traffic situations.

Performance is further enhanced by the application of Artificial Intelligence and Fuzzy Logic for statistical traffic forecasting and traffic pattern recognition tasks.

The KONE Alta™ system moves more people efficiently, comfortably, and with shorter waits and travel time.





K O N E A l t a TM

KONE Alta™ brain power

The high-speed TMS9900 GA call allocation process consists of four stages: First, the passenger flows are recorded, identified and measured for short term and daily traffic statistics. The TMS9900 GA uses Artificial Intelligence to 'learn' the traffic and to generate forecasts for each weekday. Using short- and long-term forecasts based on this knowledge, a Fuzzy Logic module generates detailed models of the prevailing traffic patterns. The measured traffic data and the momentary prevailing traffic patterns, together with actual drive time and stop time data, are then processed by the Genetic Algorithm. The result is optimized dispatching decisions and landing call allocations in all traffic situations, including the most complex and demanding mixed traffic which includes incoming, outgoing and inter-floor traffic components.

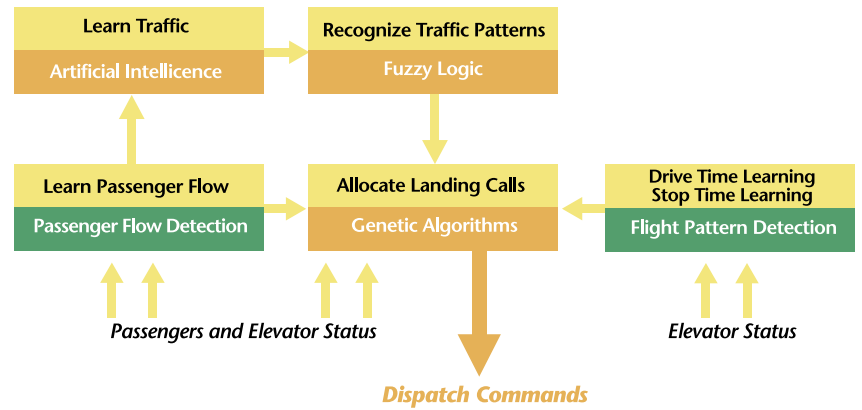

The group controller uses the fast Genetic Algorithm protocol that generates best dispatching solutions in all traffic situations.

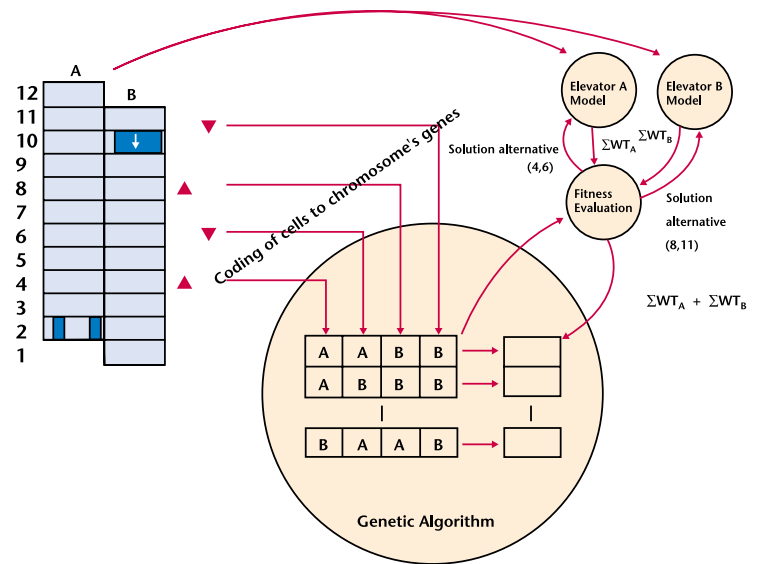
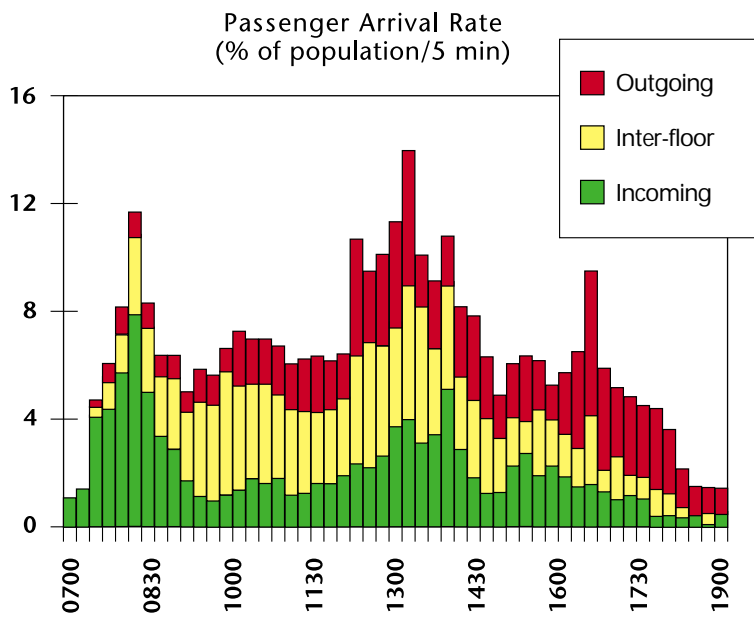

The TMS9900GA employs a SerTrans™ local area network to ensure Alta™ elevator systems operate reliably and efficiently. A comprehensive array of alternative and optional control functions and features ensure perfect match with specific individual building needs.

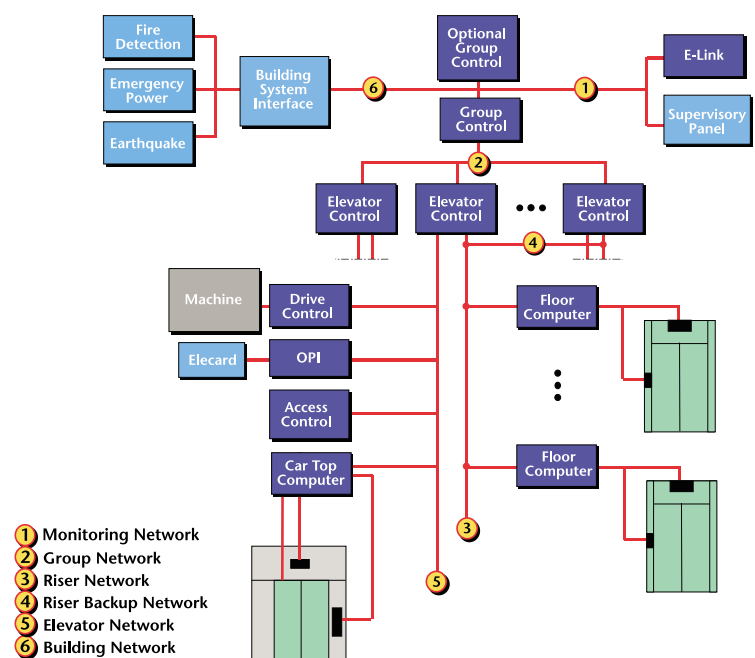

Smooth, swift and quiet

Creating perfect ride comfort in high-speed elevators is a science, requiring complete understanding of the complex forces and elements involved and how to control them to always maintain passengers well within their physiological 'comfort zone'.

KONE Alta™ technology masters all these areas; the elevators are designed, engineered, installed and verified to deliver a truly exceptional, comfortable ride. Vibrations and sways are barely perceptible. Machine, rope, guiderail and wind noises are dramatically reduced.

The motion perceived by passengers is controlled thanks to acceleration and deceleration rates tuned to customer preferences. Efficient traffic management reduces crowding in the cars and speeds call response. It is performance that is finely tuned to enhance your building.

16

15

12

10

7

5

3

K O N E A l t a™

100
50
20
10
5
2
1
0.50
0.20
0.10
0.05
0.02
0.01



For very high-speeds aerodynamic deflection shrouds are added to reduce air turbulence and noise.

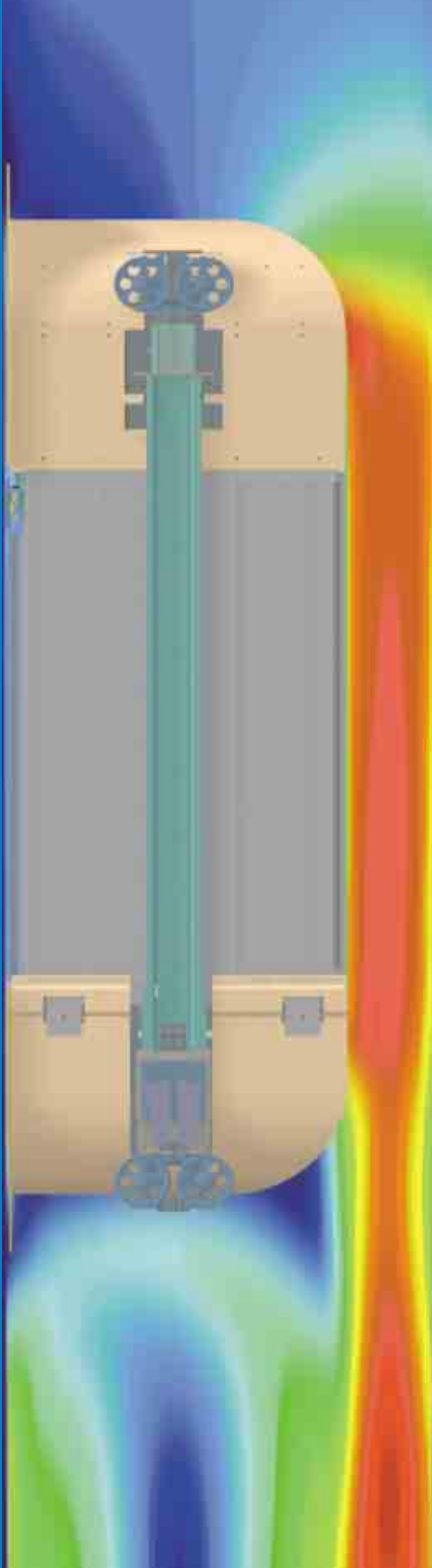

KONE Alta™ 'Triple-A' ride

A perfect elevator ride, the KONE 'AAA comfort class' is standard in Alta™ elevators. It is achieved through: –

- Well-designed componentry
- Thorough planning
- Expert installation
- Verification of the ride comfort specification.

Specially developed KONE high-rise installation methods, tools and trained specialists are essential for achieving the 'Triple-A' ride comfort class.

The main ride comfort related components are the guide rails, car structure and sling, door, roller guides. Sound attenuators help seal off machine room noise. Hoistway construction and layout are also significant factors.



Each building project presents its own special ride comfort challenges. Project planning includes correct component selection, calculating the static and dynamic balance of the elevator cars, and the preparation of carefully detailed general arrangement drawings.

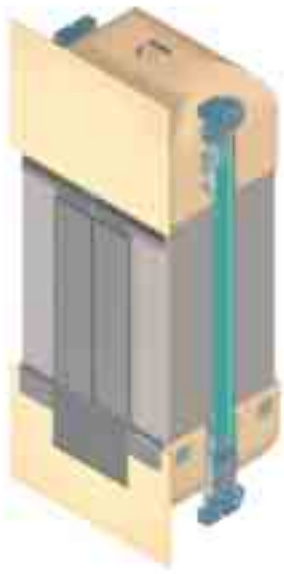

The insulated, double-wall Alta™ car enclosure eliminates up to 25dB(A) of hoistway noise and features 'tuned' ventilation. The door panels are fully insulated. Sealed door panel edges prevent air leaks and noise. The heavy-duty door operator uses the same PMSM technology as the hoisting units.



Adjustable acceleration and deceleration parameters of the V²F drive system along with the highly controllable synchronous EcoDisc® machines, allow you to select your level of performance, from brisk efficiency (solid line) to silky smooth (dotted line) take-offs and landings.

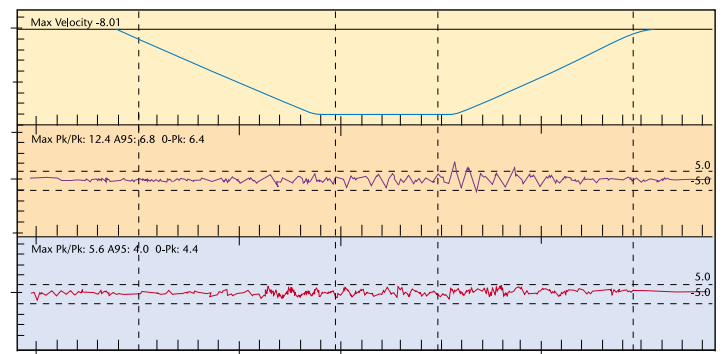
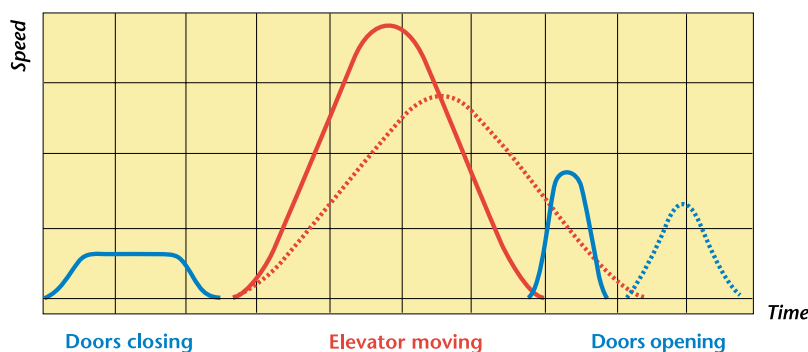

Precision instruments are used to ensure that the measured ride comfort parameters match the targeted specification.



Put your vision in motion

Your building is a statement about your goals and accomplishments. KONE Alta™ cars and landing elements allow you to extend your design visions to the elevators.

Car technology options include a re-programmable flat colour screen to display elevator data, general or floor specific building messages, emergency announcements, tenant information or advertising.

A man in a dark suit and glasses is carrying a young child on his shoulders. The child is wearing a white shirt with blue stripes and white sneakers. The man is holding a black briefcase in his right hand. They are standing in an elevator with wood-paneled walls and a stone base. The lighting is warm and focused on the man and child.

K O N E A l t a TM

Passenger perception of a building's elevators starts from total confidence in their safety; However a variety of elements combine to make each ride a pleasant experience: Easy-to-use interfaces; speedy response and travel; 'polite' doors; comfortable and airy cars, and, of course, precise, and smooth starts, runs and stops.



K O N E A l t a TM

Detail is everything ...
... in creating desired design effects and atmosphere.



Coordinated user interfaces, entrances and car finishes are offered as alternatives to individual custom designs.



3D modeling speeds up the approval process by providing photo-realistic illustrations of the proposed car designs and details before they are built.

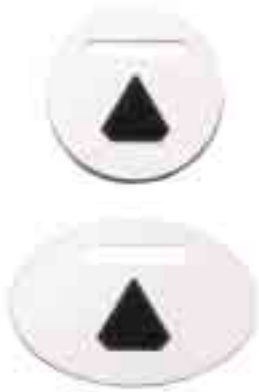

KONE – an investment in the future

The life-cycle of a building consists of five stages: Project planning, construction, interior finishing, long-term usage and eventual renewal. Our aim is to contribute to successful completion of each critical step. Project services are an integral part of our products, designed to achieve the same standard of excellence.

- Ensuring the performance, cost-effectiveness and space-efficiency of the proposed elevator and escalator solutions
- Helping define the architectural specifications
- Planning and implementing on-time installation
- Maintaining equipment to ensure reliable service and maximum availability



K O N E A l t a™

A low-angle photograph of a tall building under construction. The building is covered in scaffolding and has many windows. A yellow tower crane is positioned next to the building, and a red tower crane is visible in the lower left. The sky is blue with some clouds.

K O N E A l t a TM



The KONE way: Project partnership

Planning

Involving us in the early conceptual design process of the building gives you access to KONE's worldwide elevator and escalator experience and expertise. As standard procedure, any proposed outline specifications – the groups, car sizes, speeds and overall space requirements – are run through advanced KONE simulation and analysis systems that help optimize traffic performance, and space and cost aspects of your initial investment.



Implementation

Early completion of the building project is our mutual goal. Besides direct support by global specialist resources, our contributions include professional project management, well-planned logistics, and systematic, efficient installation by teams trained in special KONE high-rise installation methods and tools. Our support services include world leading 'jump lift' and trailing deck technology to provide elevator service during construction time to boost site productivity.



Operation

We aim to maintain the highest degree of user satisfaction in your building. This is guaranteed by the inherent quality and reliability of our products, protected by our purpose-designed preventive maintenance programs, maintained by the skills and dedication of our people and continually updated in line with inevitable future technological advancements.

KONE E-Link™ monitoring system allows constant monitoring and verification of the performance of all elevators and escalators in the building.





KONE profile

KONE is a leading company in the global elevator and escalator business. It consists of the KONE Corporation, the Finnish parent company and more than 150 subsidiaries worldwide.

Our core competence is elevators, escalators and related services. We design, engineer, install, modernize and maintain elevators and escalators, supplied by integrated production units in Europe, Asia, and North and South America.

Research and development keep us at the leading edge of elevator and escalator evolution. Our new generations of energy-efficient products have won us worldwide recognition as an innovator and technological leader. They provide material improvement in both the energy and environmental performance of buildings.

We are dedicated to reliability and innovation in serving our worldwide clients. KONE products and services are designed to increase the value and effectiveness of our customers, buildings and businesses.



KONE. The heart of tall buildings worldwide



Oslo Plaza, Oslo, Norway



City Point, London England



1000 De la Gauchetiere, Montreal, Canada



77 Wacker, Chicago



Melbourne Central, Melbourne, Australia



Oxford House, Hong Kong



88 Phillip St., Sydney, Australia



City Group, London



La Grande Arche, Paris, France



MLC Center, Sydney, Australia



Gazprom Building, Moscow, Russia



Rembrandt Tower, Amsterdam, Netherlands



www.kone.com

